

SQUEEZE ACTION PLIER CLAMPS

Sizing and Application Chart



Click
Page #
View

Series	Page MC-SAP-#	Max. Holding Capacity N [lbf.]					Maximum Clamping Thickness mm [inch]							
		0 to 1000 [0 to 225]	1000 to 2000 [225 to 450]	2000 to 3000 [450 to 675]	3000 to 4000 [675 to 900]	4000 to 5000 [900 to 1125]	5000 to 6000 [1125 to 1350]	0 to 10 [0 to 0.39]	10 to 20 [0.39 to 0.78]	20 to 30 [0.78 to 1.18]	30 to 40 [1.18 to 1.57]	40 to 60 [1.57 to 2.36]	60 to 80 [1.57 to 3.15]	80+ [2.26+]
325	2				•						•			
345	3				•									•
424	4	•						•						
441	4		•						•					
431	5	•							•					
425	6			•					•					
435	6			•						•				
462	7				•				•					
463	7				•						•			
482	7							•	•					
484	7							•				•		
486	7					•								•

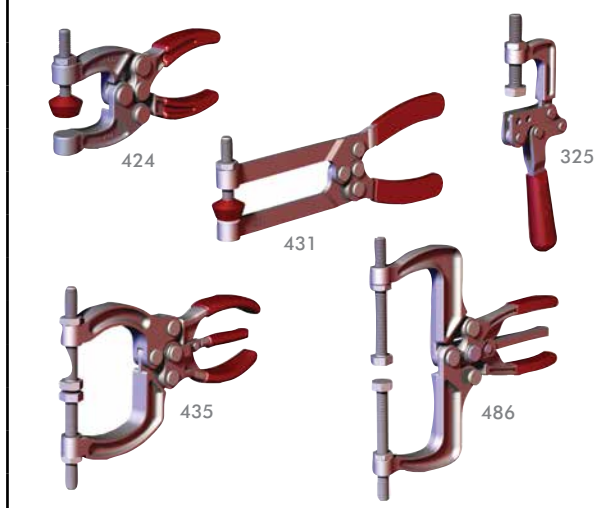

Features:

- Designed for attachment by welding or using mounting holes
- Available in stainless steel as **-SS** version

Applications:

- Molding
- Closures for doors, lids, covers

Also Available:

See page MC-ACC-1 for accessories

325,
325-SS



Technical Information | Holding Capacities

Model	Max. Holding Capacity	Weight	Jaw Opening	Spindle (Supplied)
325	3560 N [800 lbf]	0,54kg [1.18lb]	90°	325203-M
325-SS				325943-M

Dimensions

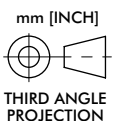
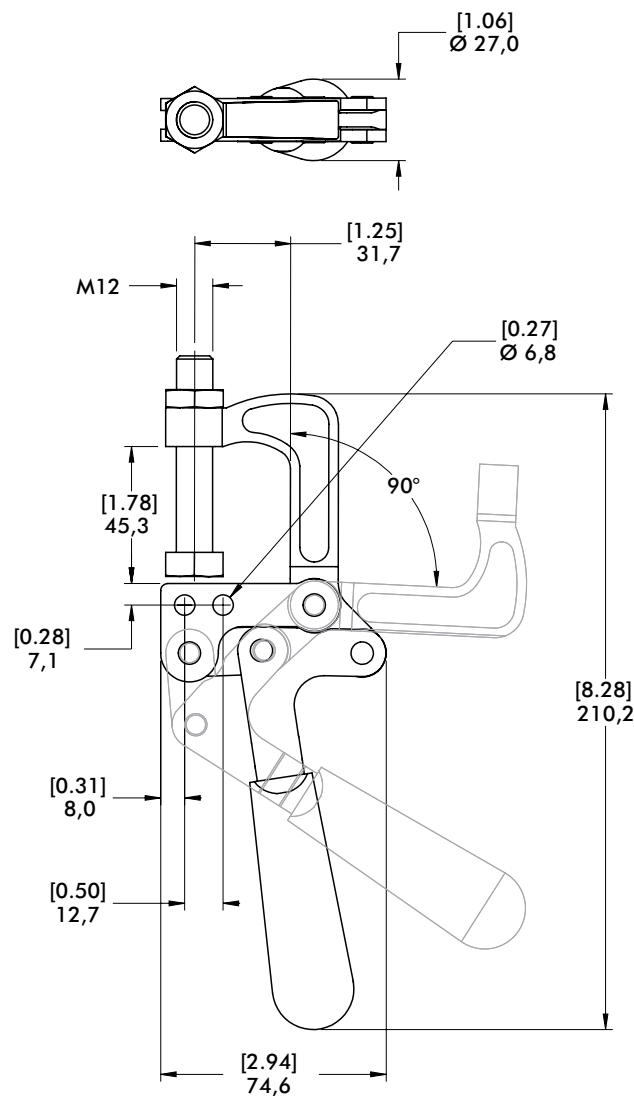

345 SERIES

Squeeze Action Plier Clamps | Product Overview

Features:

- Designed for welding or bolting at any point along the mounting bar
- Includes M10 swivel foot spindle
- Model 345-G includes sliding jaw with spindle

Applications:

- Welding fixtures
- Assembly fixtures
- Closures for doors, lids, covers

Also Available:

See page MC-ACC-1 for accessories

345,
345-G ⓘ



Technical Information | Holding Capacities

Model	Max. Holding Capacity	Weight	Jaw Opening	Spindle (Supplied)
345	3560 N [800 lbf]	1,22kg [2.69lb]	85°	468206-M
345-G ⓘ		1,40kg [3.09lb]		468206-M 210203-M

ⓘ This item is available upon request.

Dimensions

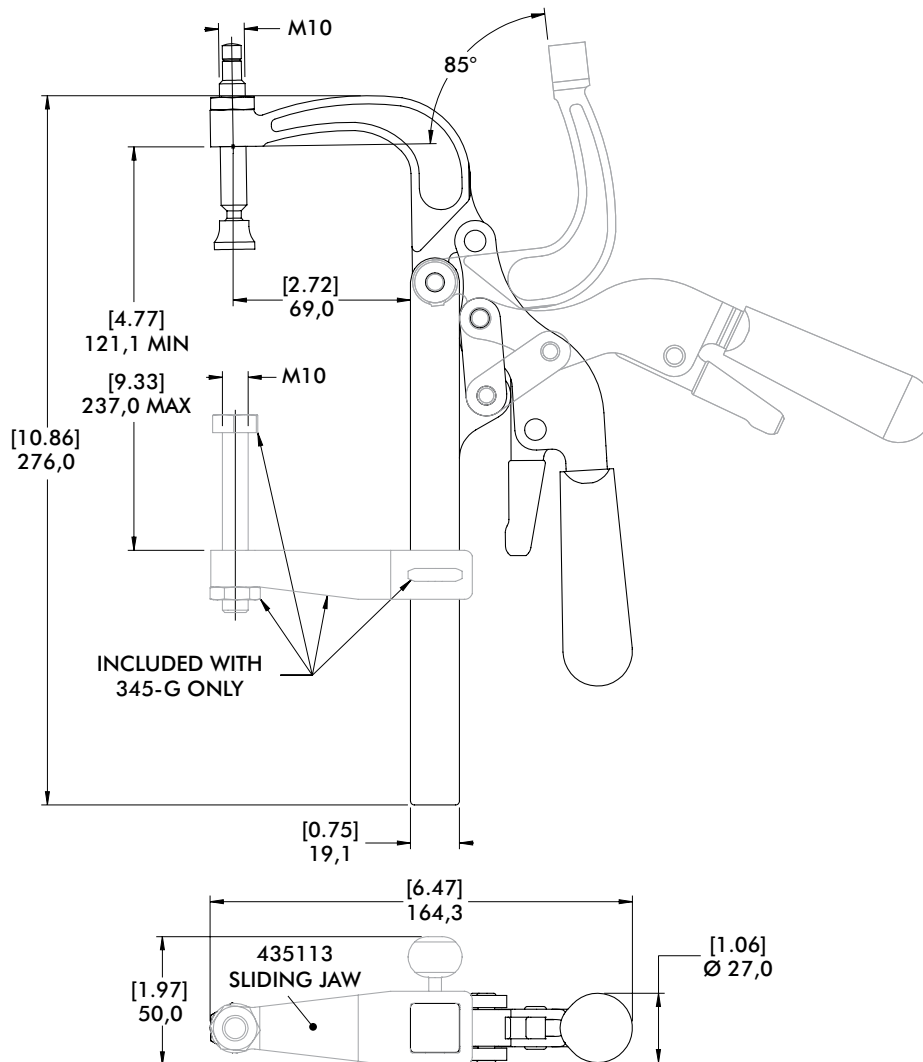

mm [INCH]
THIRD ANGLE PROJECTION

424, 441 SERIES

Squeeze Action Plier Clamps | Product Overview

Features:

- Compact clamps with forged alloy steel construction for high strength
- Versions ending with (-2) are supplied with two adjustable spindles

Applications:

- Welding
- Assembly

Also Available:

See page MC-ACC-1 for accessories

424



424-2

With Two Adjustable Spindles



441



441-2

With Two Adjustable Spindles



Technical Information | Holding Capacities | Dimensions

Model	Max. Holding Capacity	Weight	(K5) Maximum Clamping Thickness	Spindle (Supplied)
424	900 N [200 lbf]	0,14kg [0.31lb]	16 [0.63]	424208-M
424-2			7,4 [0.29]	(2X) 431208-M
441	1560 N [350 lbf]	0,29kg [0.63lb]	23,3 [1.03]	441203-M
441-2			20,8 [0.82]	(2X) 461203-M

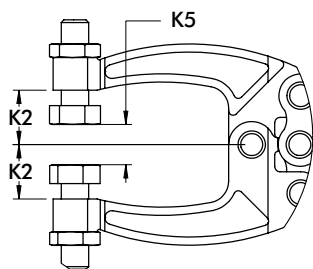

MODEL 424-2 & 441-2 AS SHOWN

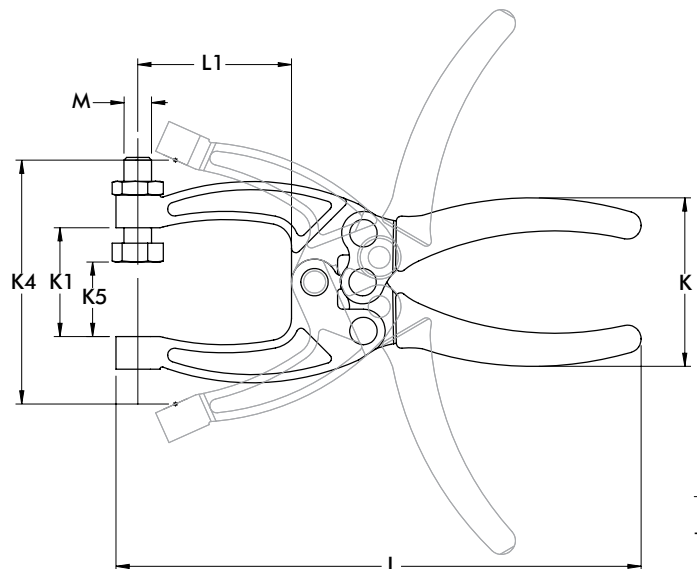
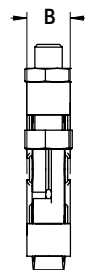

mm [INCH]
THIRD ANGLE PROJECTION

Model	B	K	K1	K2	K4	L	L1	M
424	[0.66]	[1.91]	[1.00]	[0.50]	[2.06]	[4.63]	[1.08]	M6
424-2	16.8	48.5	25.4	12.7	52.3	117.6	27.4	M6
441	[0.50]	[2.07]	[1.25]	[0.63]	[2.80]	[6.03]	[1.77]	M8
441-2	12.7	52.5	31.8	15.9	71.2	153.1	44.9	M8

431 SERIES

Squeeze Action Plier Clamps | Product Overview

Features:

- Tempered spring steel jaws provide exceptional jaw depth

Applications:

- Assembly
- Gluing, soldering

Also Available:

See page MC-ACC-1 for accessories

431



Technical Information | Holding Capacities | Dimensions

Model	Max. Holding Capacity	Weight	(K5) Maximum Clamping Thickness	Spindle (Supplied)
431	400 N [100 lbf]	0,14kg [0.31lb]	6,8 [0.27]	424208-M

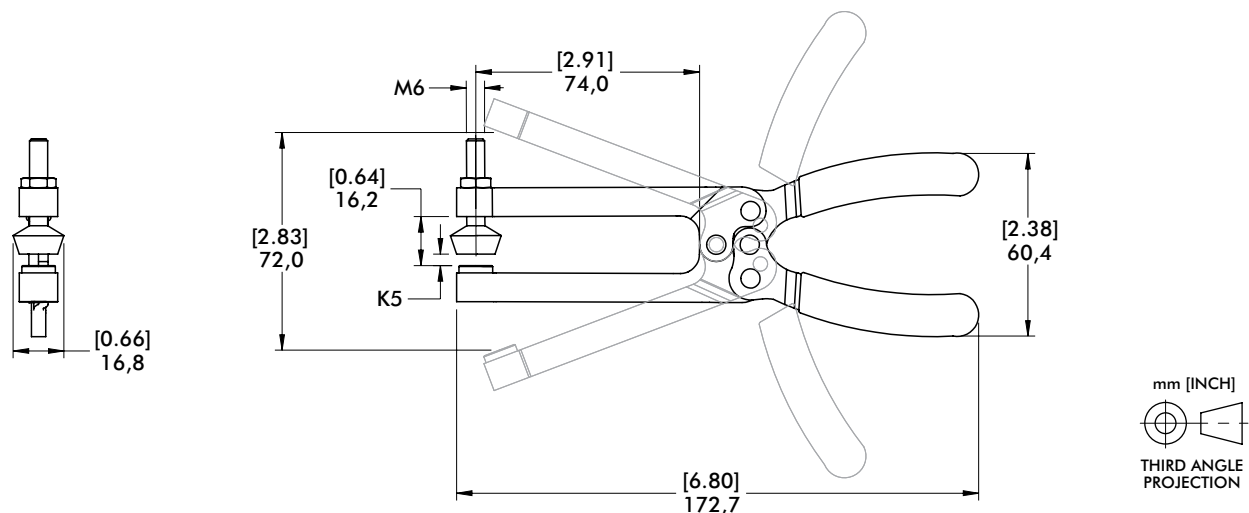

425, 435 SERIES

Squeeze Action Plier Clamps | Product Overview

Features:

- Two way trigger release allows for fast and easy opening of clamp

Applications:

- Assembly
- Welding
- Gluing, soldering

Also Available:

See page MC-ACC-1 for accessories

425 ⓘ



435



Technical Information | Holding Capacities | Dimensions

Model	Max. Holding Capacity	Weight	(K5) Maximum Clamping Thickness	Spindle (Supplied)
425 ⓘ	2220 N [500 lbf]	0,14kg [0.31lb]	24 [0.94]	205203-M
435		0,23kg [0.50lb]	36,3 [1.43]	(2X) 205203-M

ⓘ This item is available upon request

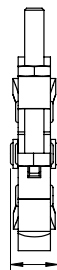

[0.58]
14,8

MODEL 425 AS SHOWN

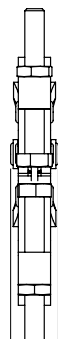
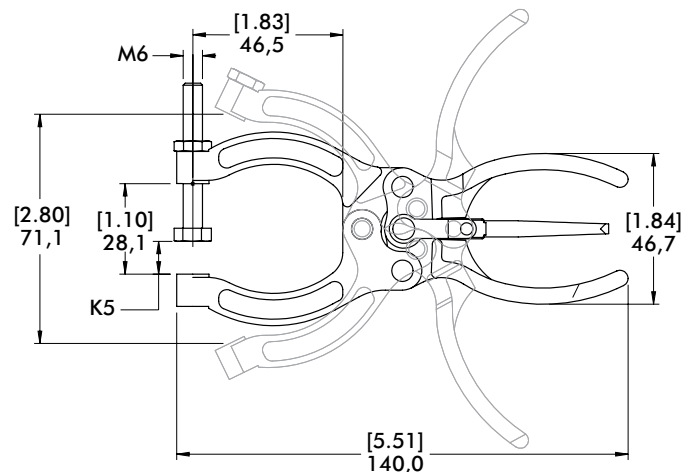

[0.58]
14,8

MODEL 435 AS SHOWN

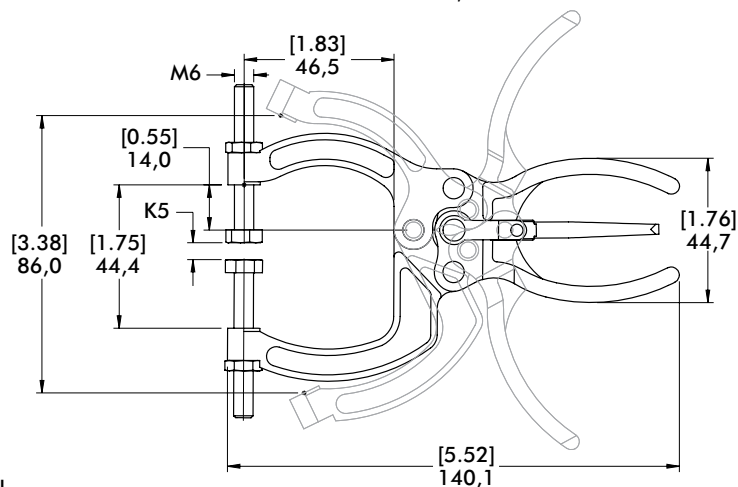

mm [INCH]
THIRD ANGLE PROJECTION

460, 480 SERIES

Squeeze Action Plier Clamps | Product Overview

Features:

- Drop forged alloy steel components for exceptional strength
- Two way trigger release allows for fast and easy opening of clamp

Applications:

- Assembly
- Welding

Also Available:

See page MC-ACC-1 for accessories

462



462-2

With Two Adjustable Spindles



463



482



484



486



Technical Information | Holding Capacities

Model	Max. Holding Capacity	Weight	(K5) Maximum Clamping Thickness	Spindle (Supplied)
462	3110 N [700 lbf]	0,51kg [1.13lb]	29,5 [1.16]	468206-M 210206-M
462-2			30,5 [1.20]	(2X) 491203-M
463		0,54kg [1.19lb]	54,2 [2.13]	468206-M 210206-M
482	5340 N [1200 lbf]	0,79kg [1.75lb]	29,5 [1.16]	468206-M
484			0,91kg [2.00lb]	76,5 [3.01]
486		1,05kg [2.31lb]	138,4 [5.45]	(2X) 240203-M

460, 480 SERIES

Squeeze Action Plier Clamps | Dimensions

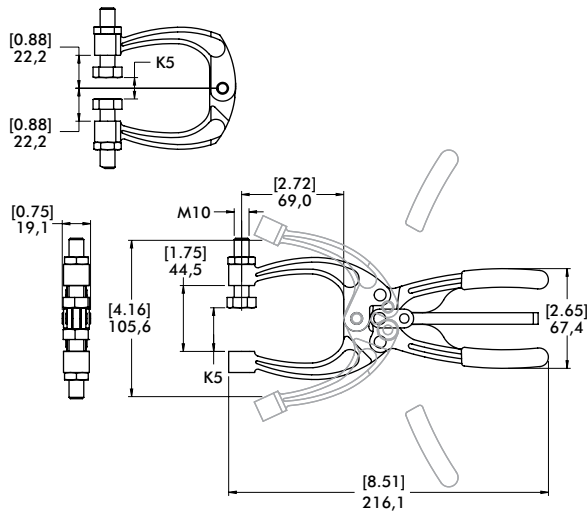

MODEL 462 AS SHOWN

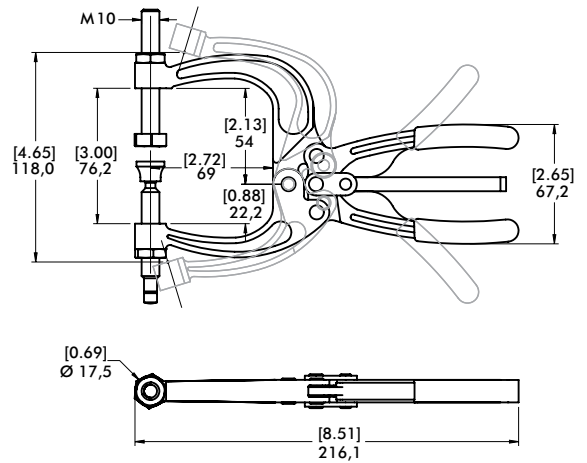

MODEL 463 AS SHOWN

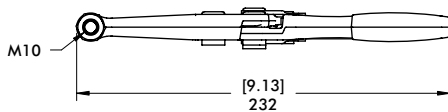

MODEL 482 AS SHOWN

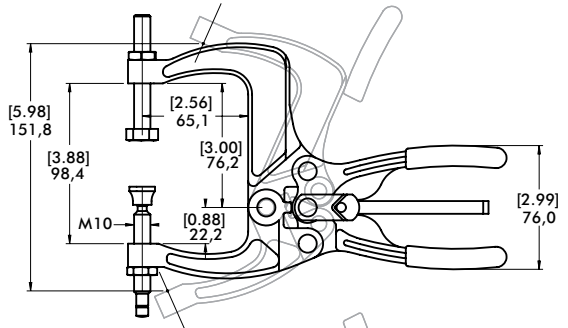
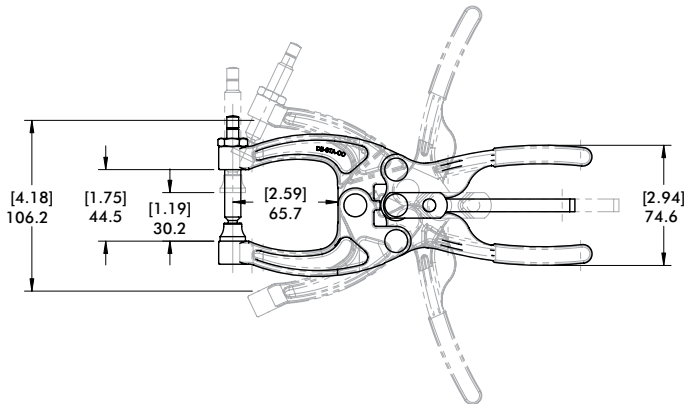

MODEL 484 AS SHOWN

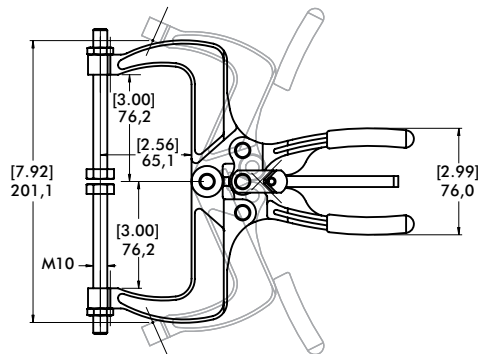
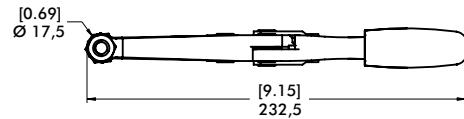

MODEL 486 AS SHOWN

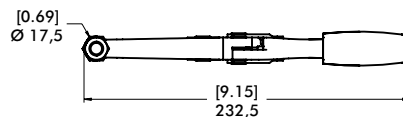

mm [INCH]

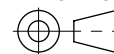

THIRD ANGLE PROJECTION