

# BAG GRIPPING AND PALLETIZING SOLUTIONS

## DBG Series

DESTACO DBG Series bag gripping end effector solutions offers end of line pick and place and palletizing solutions. The DBG has a simplified design with field adjustable finger position and opening angle.

### Features also include:

- Pneumatic or electric fully enclosed actuators
- Integrated open/closed position sensors
- Standard off-the-shelf components

### Two sizes available:

- DBG50** (50lb Max Load)
- DBG100** (100lb Max Load)

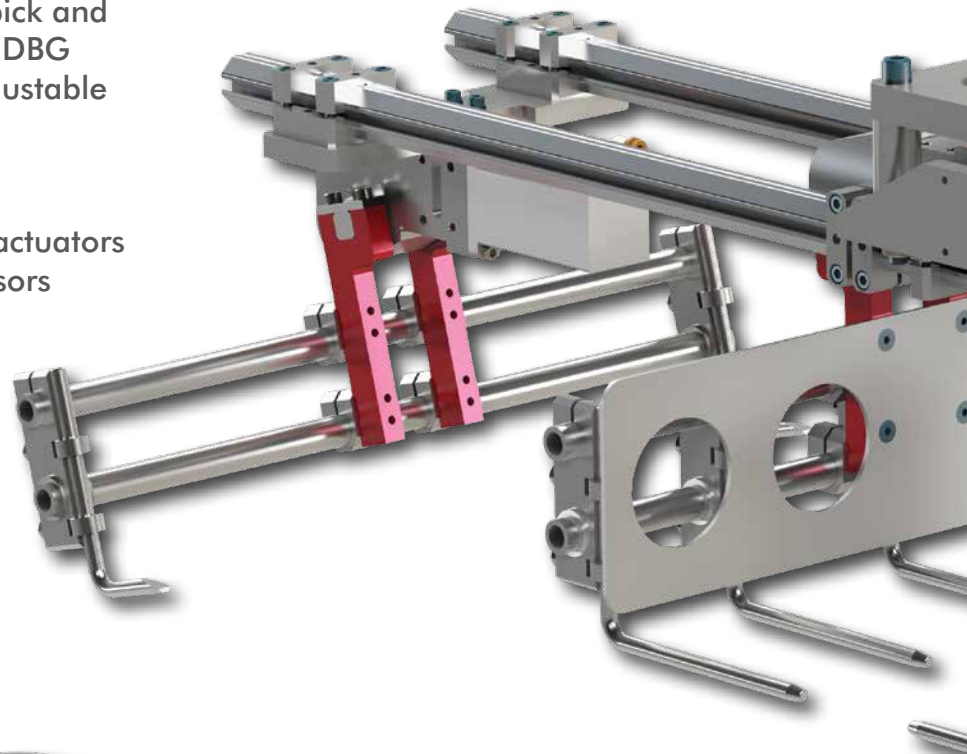

Customer Specified  
Robot Mounting Pattern

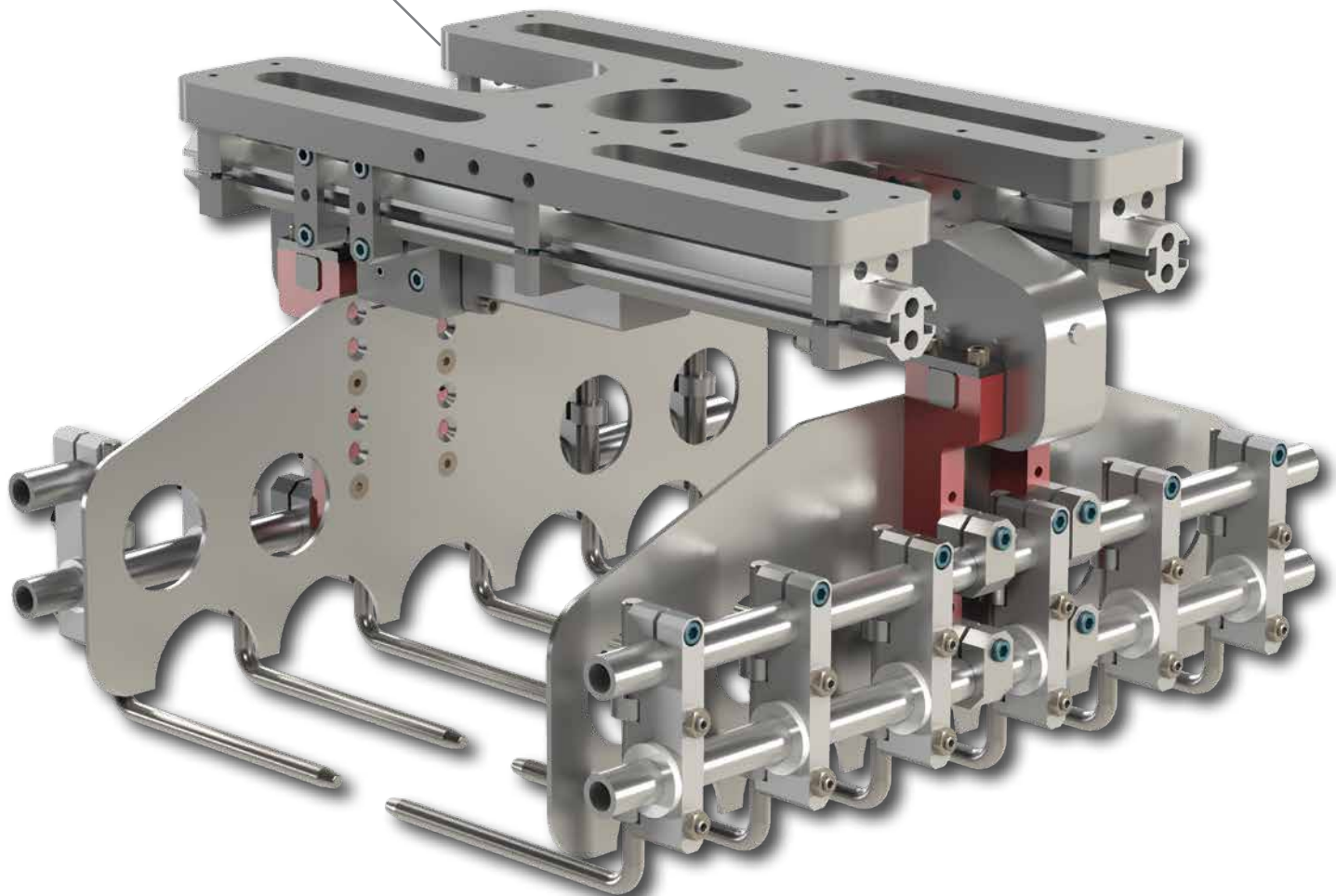

# BAG GRIPPING AND PALLETIZING SOLUTIONS

DBG Series

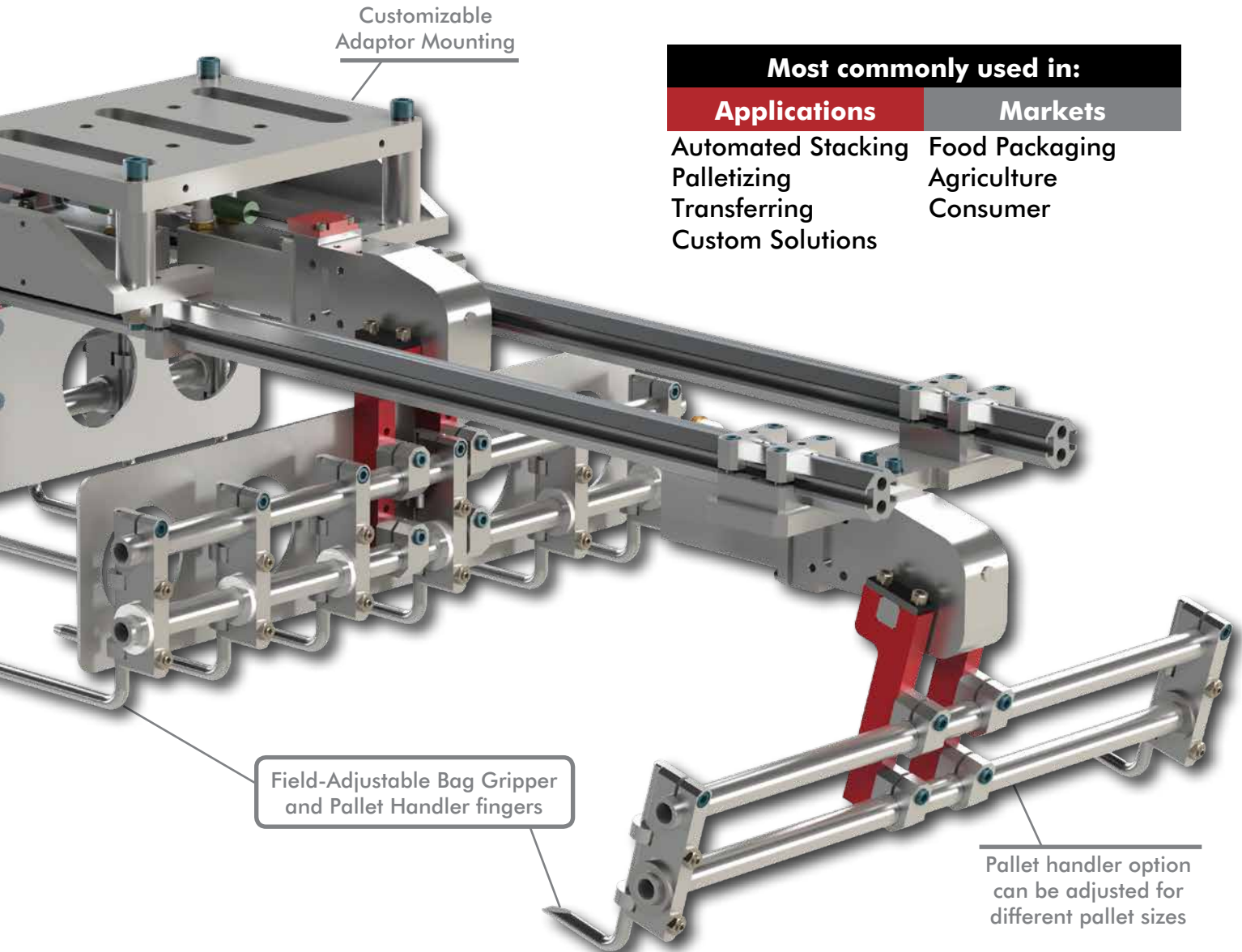

## Most commonly used in:

### Applications

Automated Stacking  
Palletizing  
Transferring  
Custom Solutions

### Markets

Food Packaging  
Agriculture  
Consumer

DESTACO DBG Series bag gripper also features optional integrated slip sheet and pallet handling. Products are held secure even if air pressure is lost.

With rapid actuation, the DBG can palletize up to 30 bags per minute when working in concert with robotic automation.

DESTACO also provides custom design and build solutions for handling any packaging transfer and palletizing needs.



# DBG SERIES BAG GRIPPER

## Product Overview

Robot Mount Stand-Off  
(Sold Separately)

Pneumatic Slip Sheet Pick Option (PU6-SP)

Additional Available Options (DBG100):

Pneumatic Back-up Option (PU6-BU)

Spring Back-up Option (SU3)

Controls Option (CP)

Pallet Pick Option (PP)

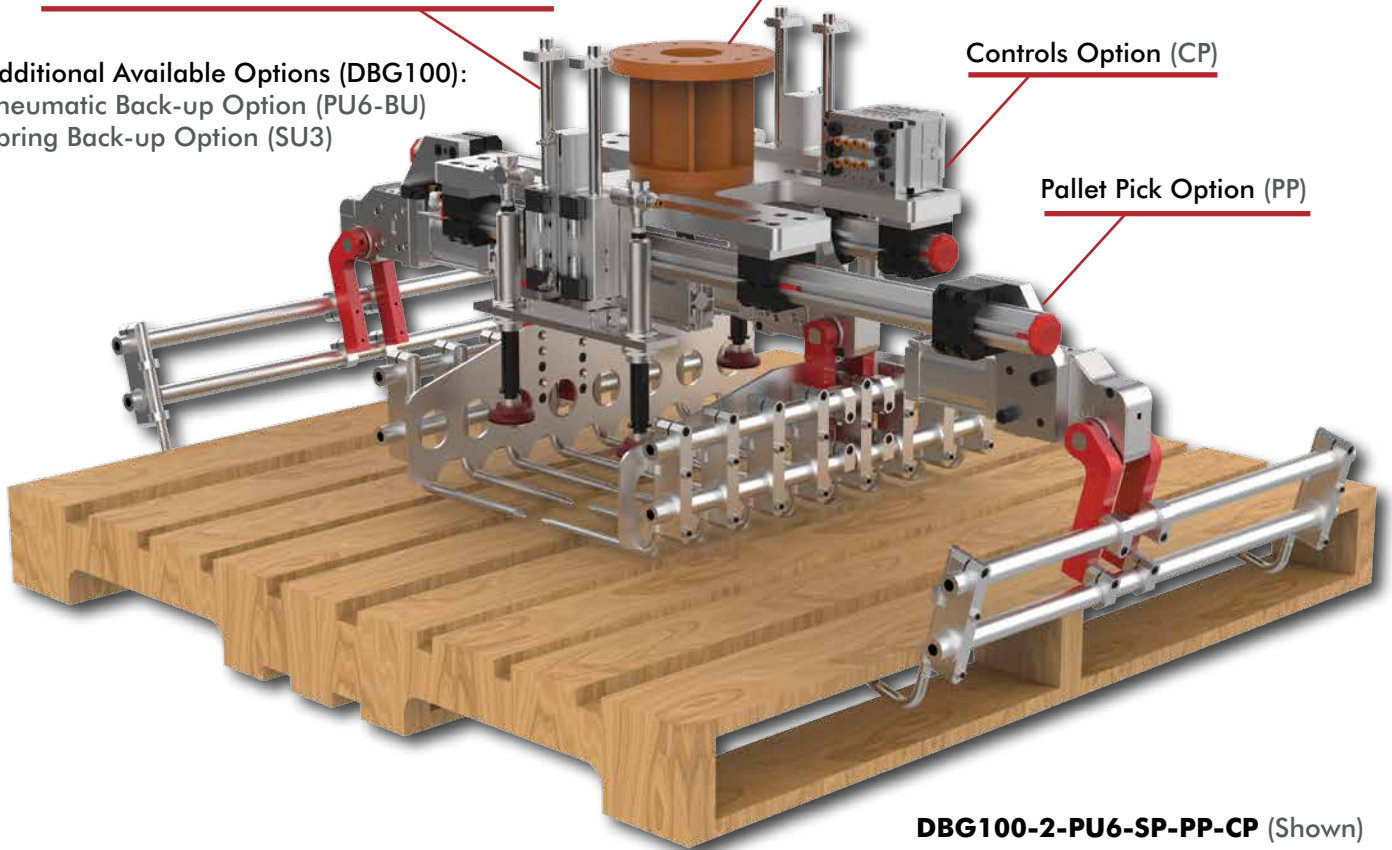

**DBG100-2-PU6-SP-PP-CP** (Shown)

Spring Back-up Option (SU2)

Additional Available Options (DBG50):

Pneumatic Back-up Option (PU4-BU)

Pneumatic Slip Sheet Pick Option (PU4-SP)

Controls Option (CP)

Pallet Pick Option (PP)

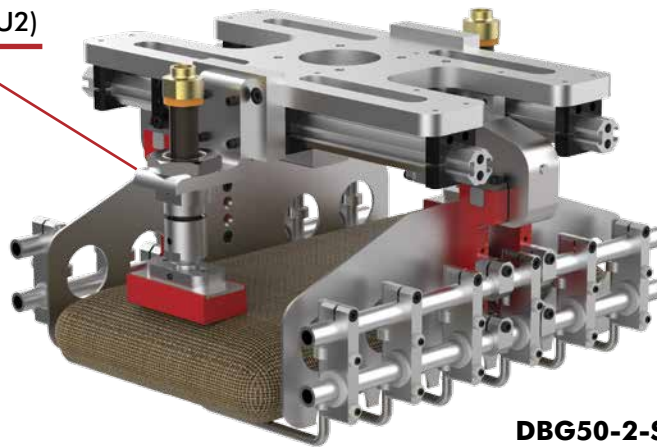

**DBG50-2-SU2** (Shown)



Scan the QR Codes to see the bag gripper application videos.

# DBG SERIES BAG GRIPPER

Base Models

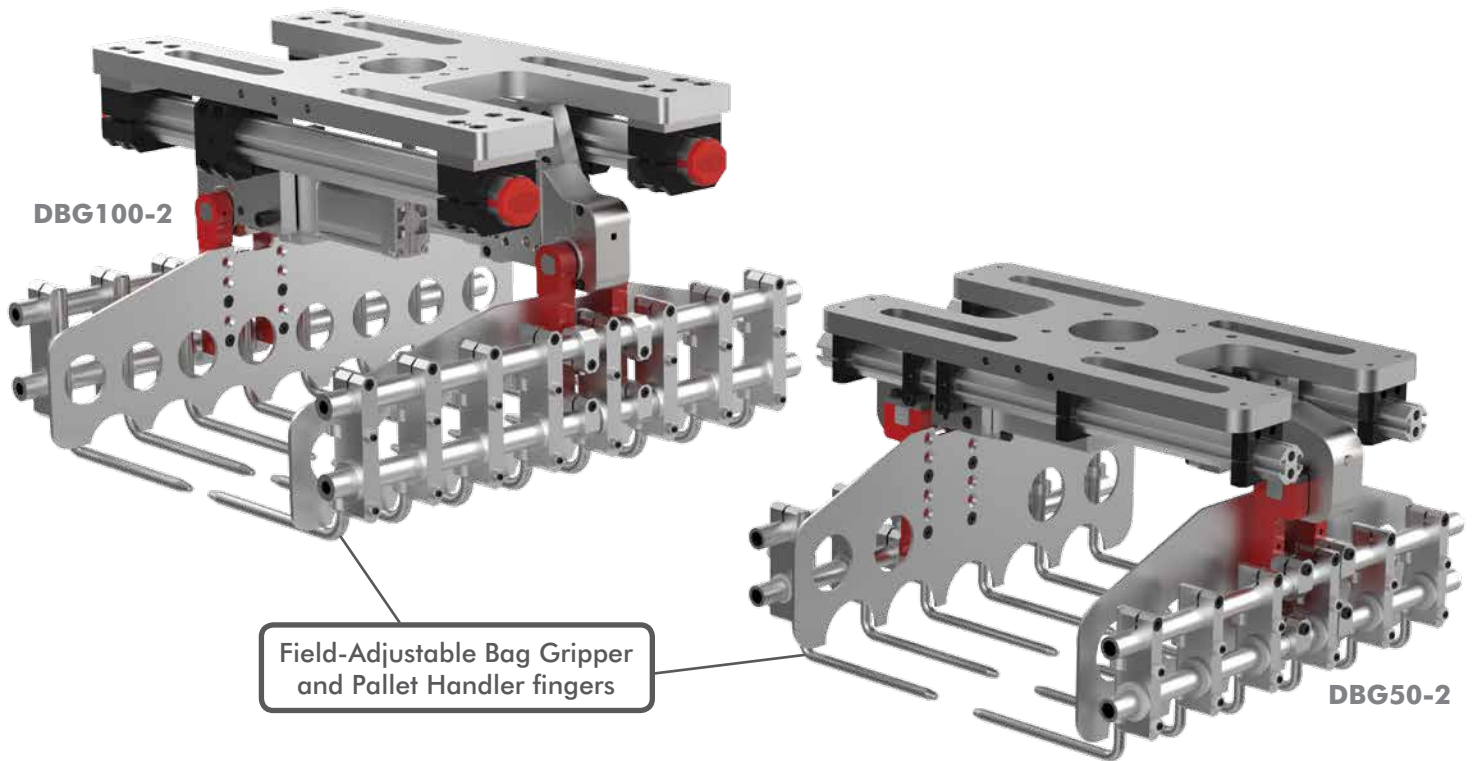

DBG Series Bag Grippers		
Specifications	DBG50-2	DBG100-2
Unit Weight:	17kg [38 lbs]	43kg [95 lbs]
Maximum Payload:	23Kg [50 lbs]	45Kg [100 lbs]
Maximum Bag Size:	432 x 711 x 122mm [17 x 28 x 5 in]	610 x 1016 x 170mm [24 x 40 x 6.7 in]

## DBG Bag Gripper Order Information

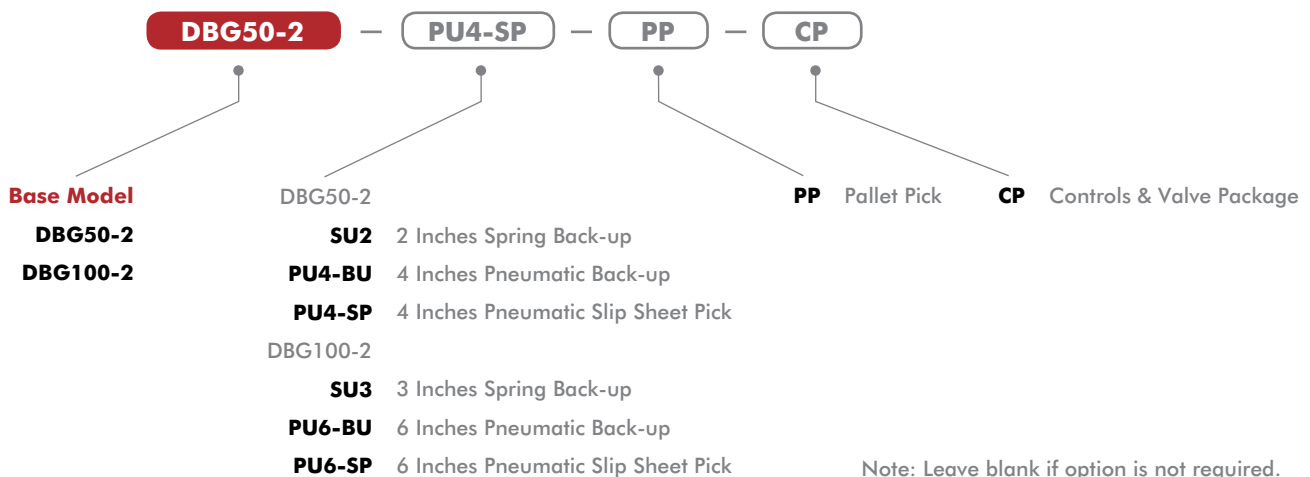

# DBG SERIES BAG GRIPPER

## Options

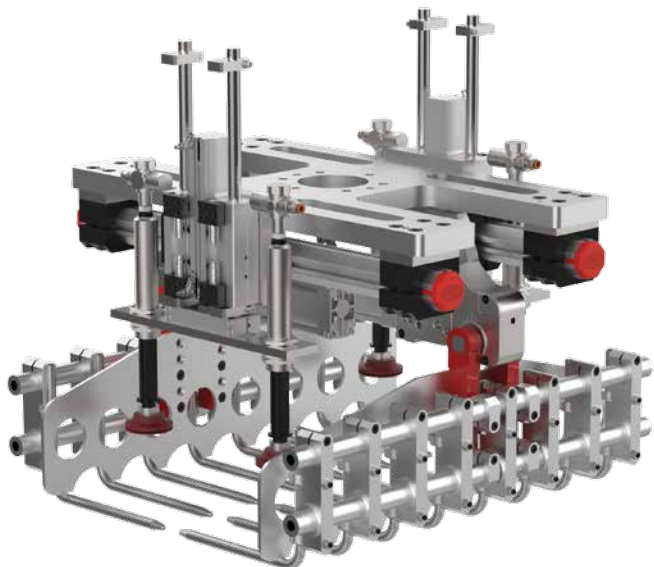

### PU(x)-SP Pneumatic Slip Sheet Pick Option

- In addition to the spring compensator option, a vacuum system can be added to the package which will handle the slip sheet.
- Eliminate the need for a second end effector or secondary operation.
- 4" Stroke for DBG50-2 (PU4-SP)  
(Add option weight of 5kg [11 lbs] to base model)
- 6" Stroke for DBG100-2 (PU6-SP)  
(Add option weight of 10kg [23 lbs] to base model)

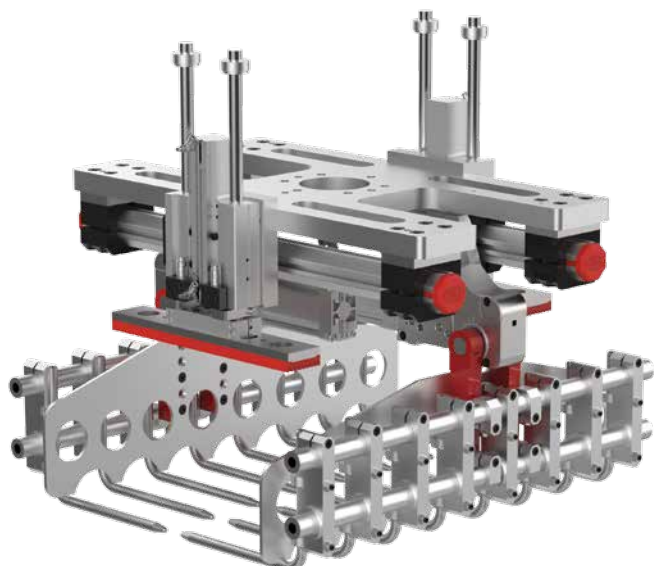

### PU(x)-BU Pneumatic Back-Up Option

- The pneumatic compensator is extended to contact the product for additional stability and control while in motion.
- 4" Stroke for DBG50-2 (PU4-BU)  
(Add option weight of 3.6kg [8 lbs] to base model)
- 6" Stroke for DBG100-2 (PU6-BU)  
(Add option weight of 9kg [20 lbs] to base model)

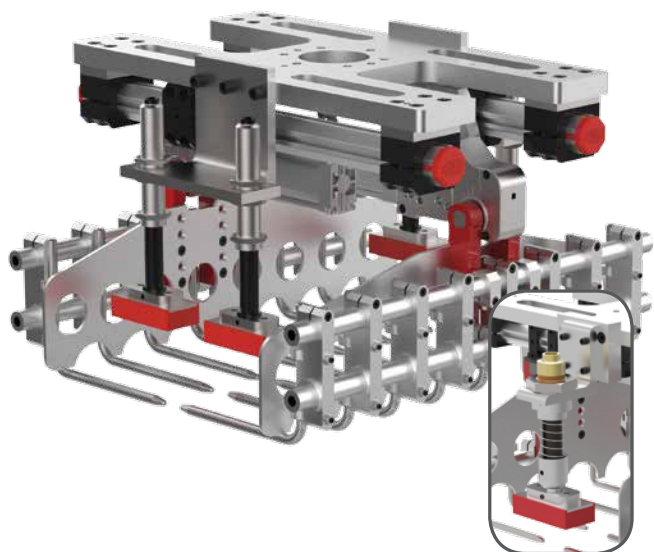

### SU(x) Spring Back-Up Option

- Simple, cost-effective solution.
- Compression springs keep a constant pressure on the product.
- Low cost solution maintains control of the product while in transport.
- Spring Back-Up Option for DBG50-2 (SU2)  
(Add option weight of 2.9kg (6.4 lbs) to base model)
- Spring Back-Up Option for DBG100-2 (SU3)  
(Add option weight of 5.6kg (12.4 lbs) to base model)

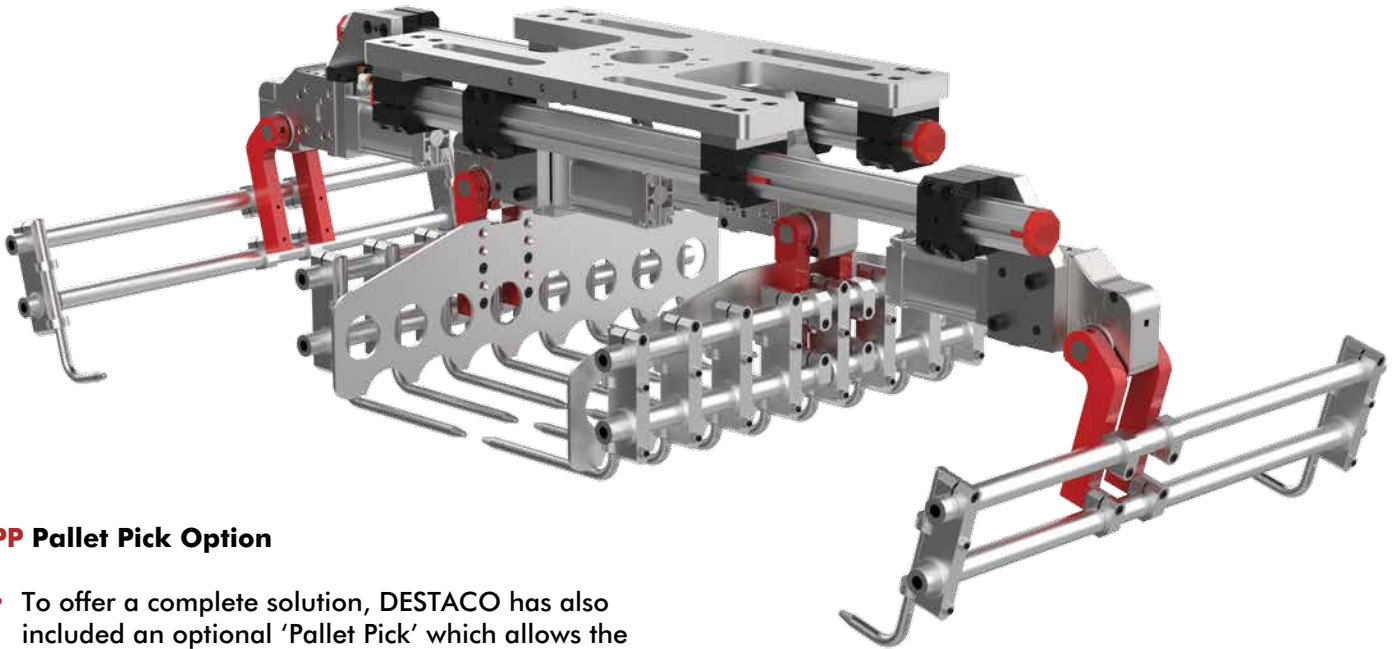

### PP Pallet Pick Option

- To offer a complete solution, DESTACO has also included an optional 'Pallet Pick' which allows the customer to pick-up and move the empty pallet.
- Pallet Pick Option for DBG50-2  
(Add option weight of 13kg [29 lbs] to base model)
- Pallet Pick Option for DBG100-2  
(Add option weight of 22kg [48 lbs] to base model)

---

### CP Controls Option

- Controls Options are configured based on the different bag gripper options ordered.  
(Add option weight of 2.3kg [5 lbs] to base model)

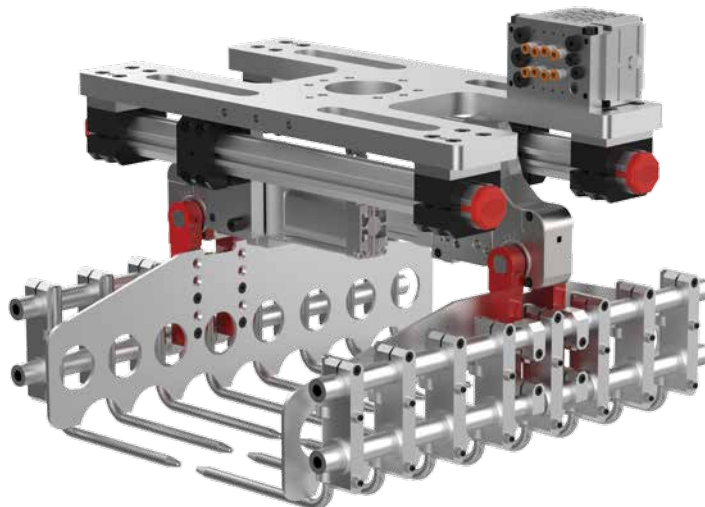

# DBG50 SERIES

## Bag Gripping and Palletizing Solutions | Dimensions

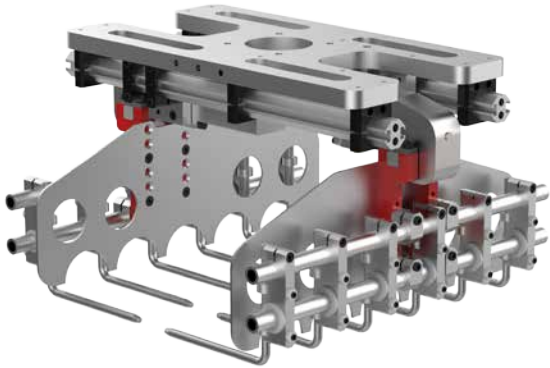

Model Number	Weight
<b>DBG50-2</b>	[38 lb] 17 kg

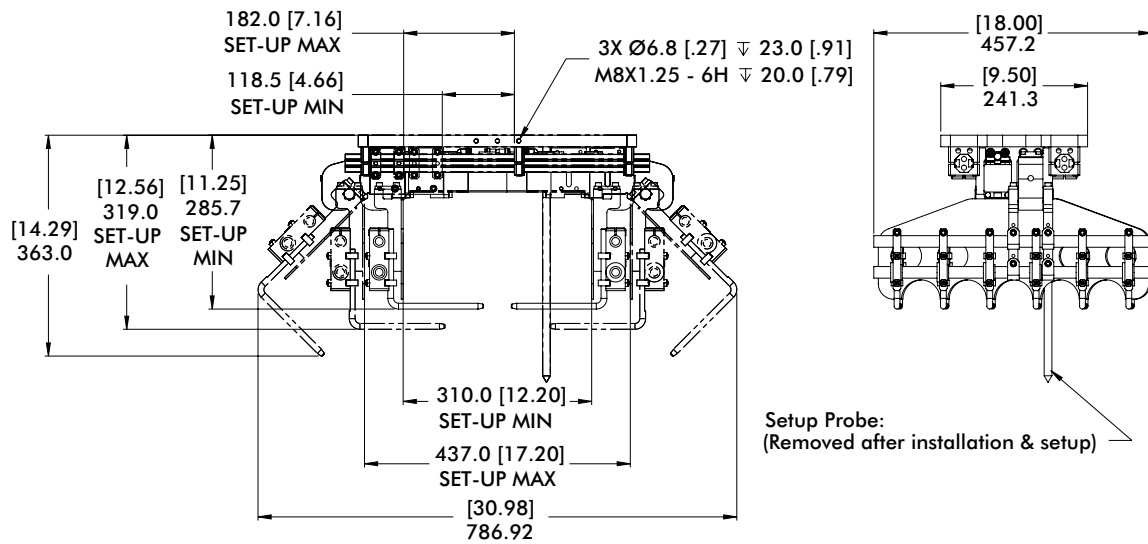
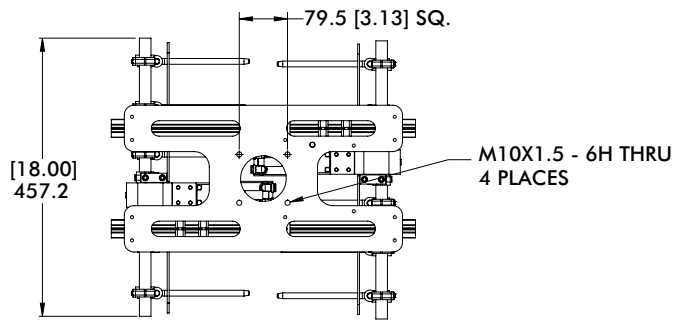

Note: mm/[Inches]

# DBG100 SERIES

## Bag Gripping and Palletizing Solutions | Dimensions

Model Number	Weight
<b>DBG100-2</b>	[95 lb] 43 kg

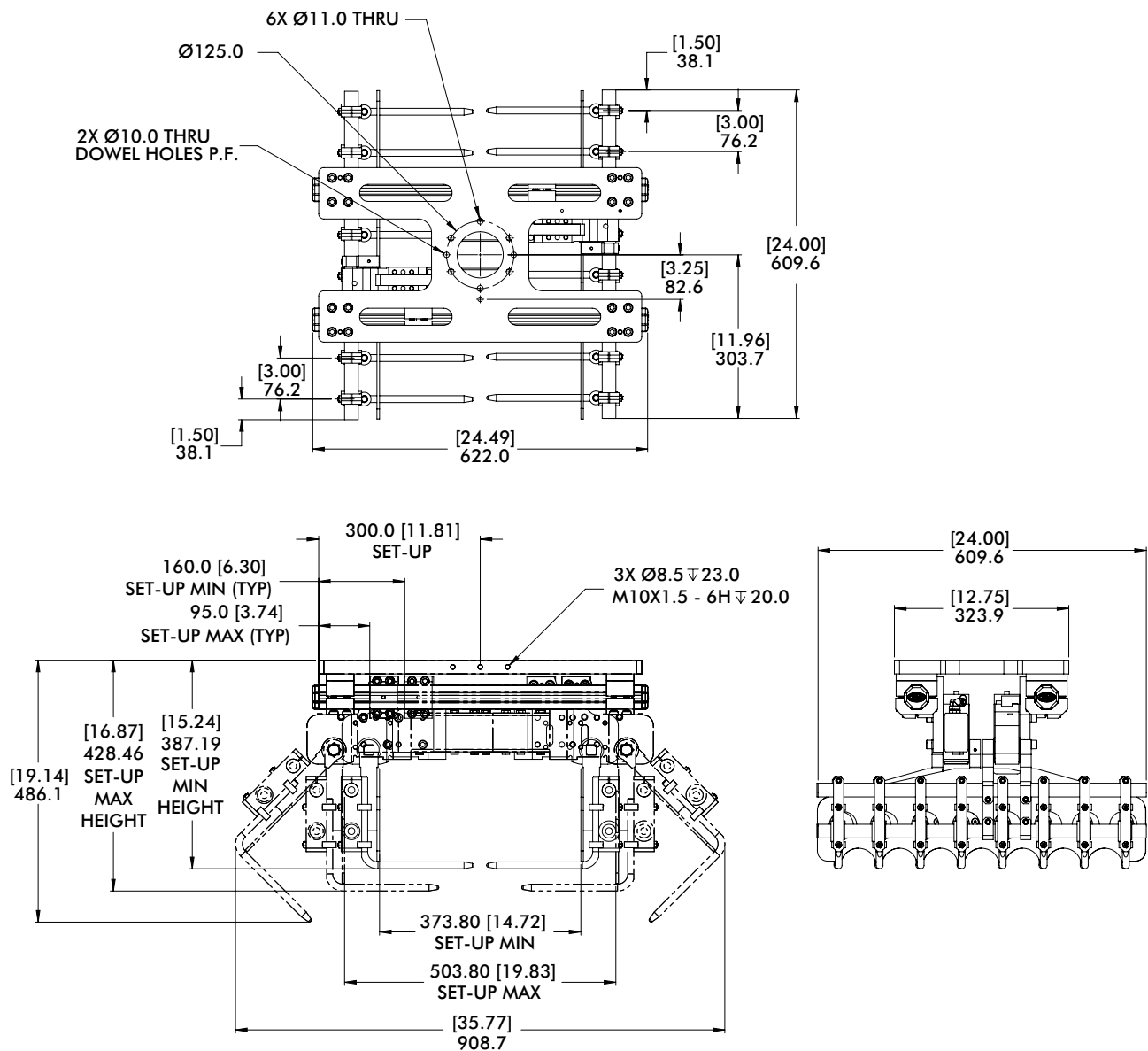
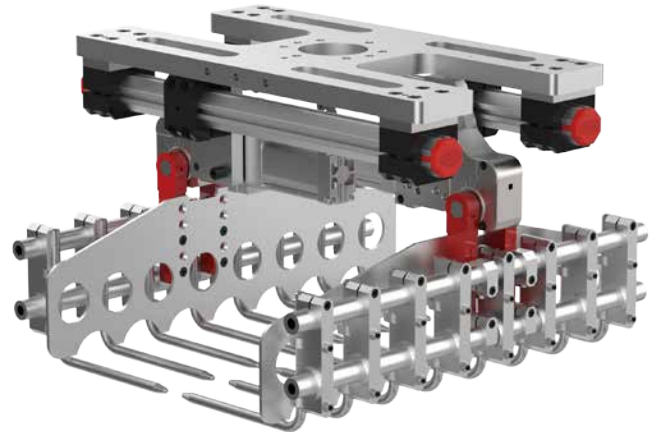

Note: mm/[Inches]



# SLIP SHEET PICK AND PLACE OPTION

Bag Gripping and Palletizing Solutions | Dimensions

4.00" [101.6mm]

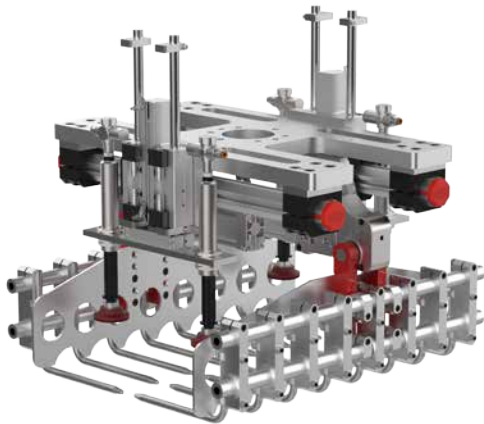

Model Number	Weight
<b>DBG50-2-PU4-SP</b>	[11 lb] 5 kg

Add to base model weight

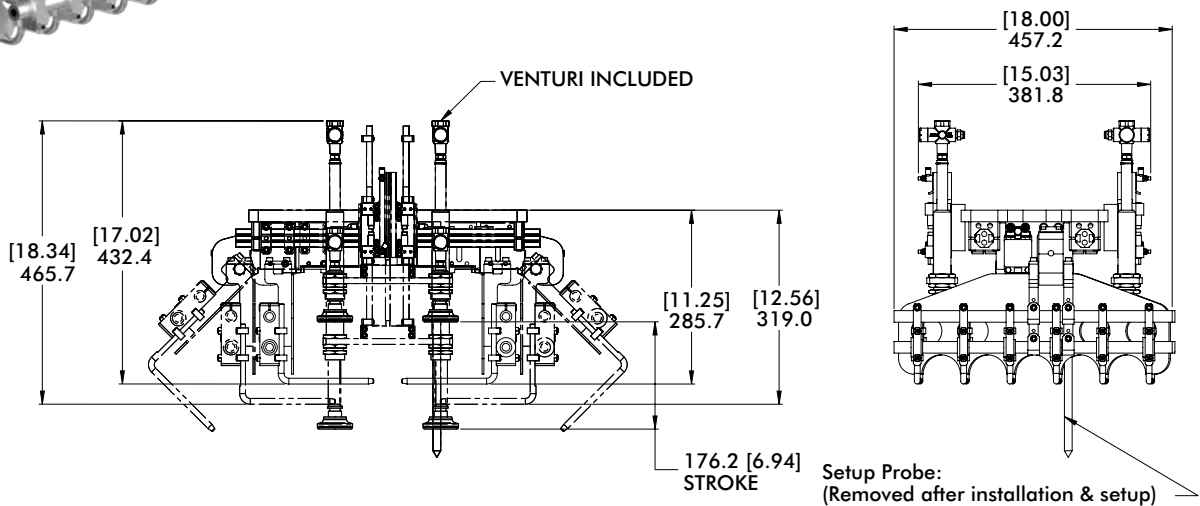

6.00" [152.4mm]

Model Number	Weight
<b>DBG100-2-PU6-SP</b>	[23 lb] 10 kg

Add to base model weight

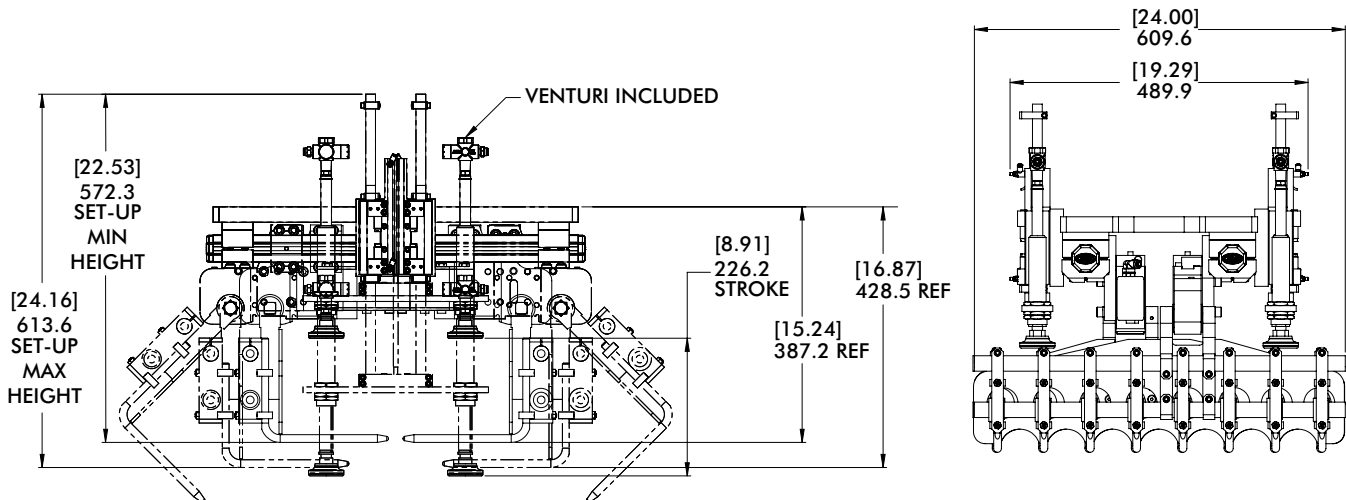

Note: mm/[Inches]

# PNEUMATIC BACK-UP OPTION

Bag Gripping and Palletizing Solutions | Dimensions

4.00" [101.6mm]

Model Number	Weight
<b>DBG50-2-PU4-BU</b>	[8 lb] 3.6 kg

Add to base model weight

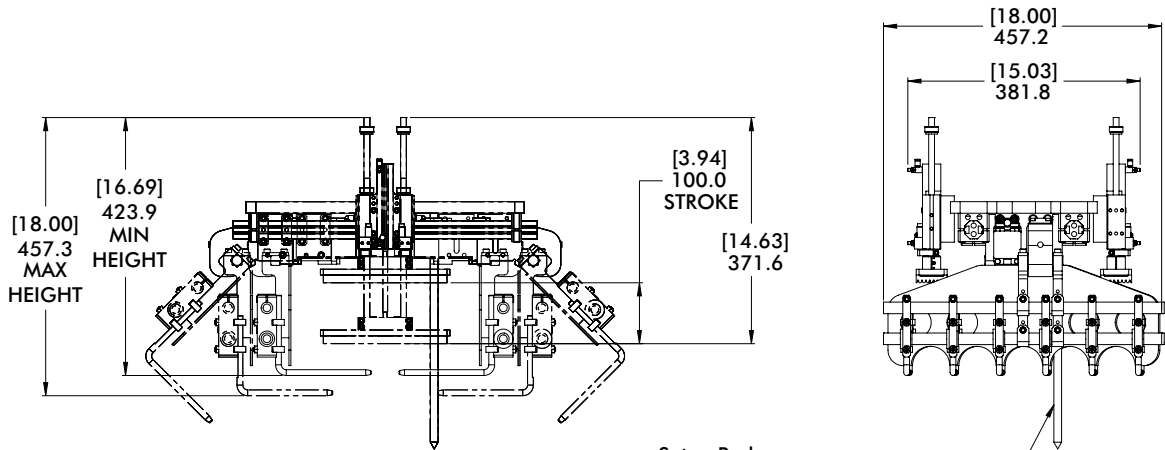
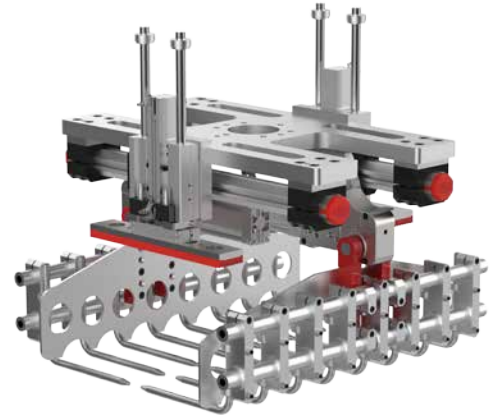

Setup Probe:  
(Removed after installation & setup)

6.00" [152.4mm]

Model Number	Weight
<b>DBG100-2-PU6-BU</b>	[20 lb] 9 kg

Add to base model weight

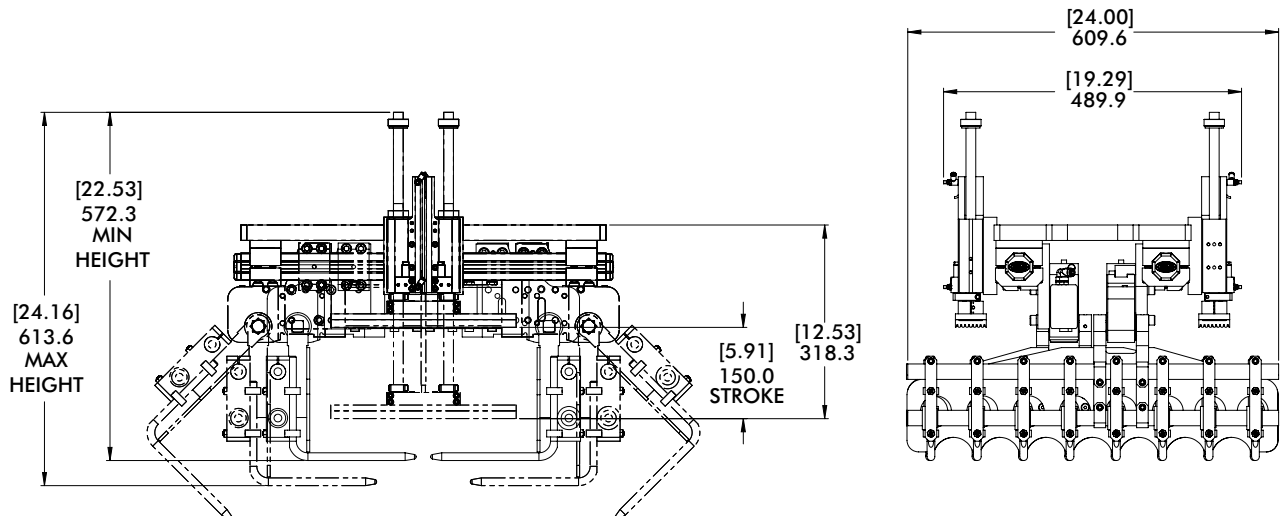

Note: mm/[Inches]

# TRAVEL SPRING BACK-UP OPTION

Bag Gripping and Palletizing Solutions | Dimensions

2.00" [50.8mm]

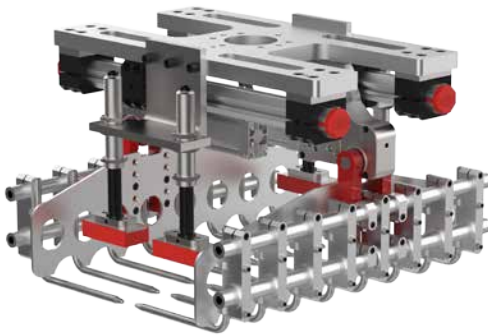

Model Number	Weight
<b>DBG50-2-SU2</b>	[6.4 lb] 2.9 kg

Add to base model weight

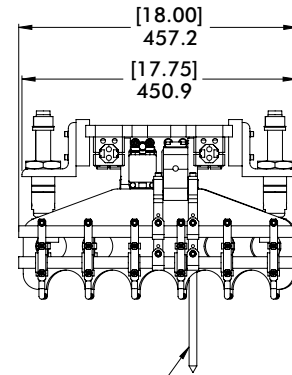
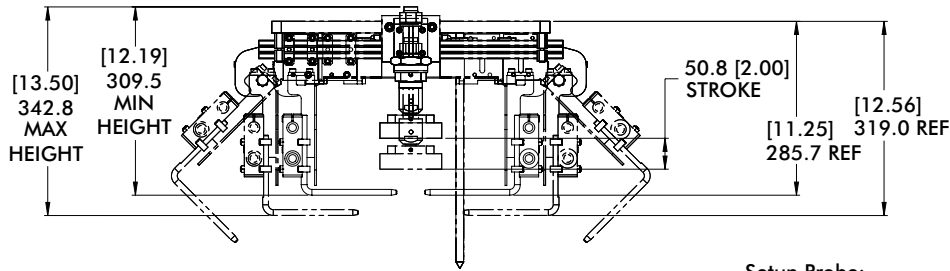

Setup Probe:  
(Removed after installation & setup)

3.00" [76.2mm]

Model Number	Weight
<b>DBG100-2-SU3</b>	[12.4 lb] 5.6 kg

Add to base model weight

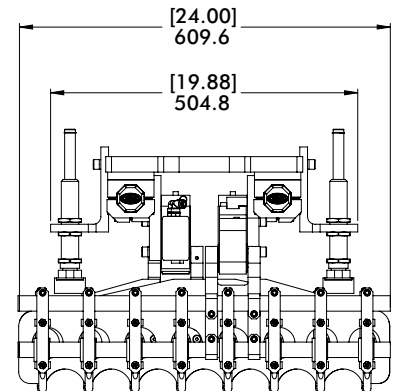
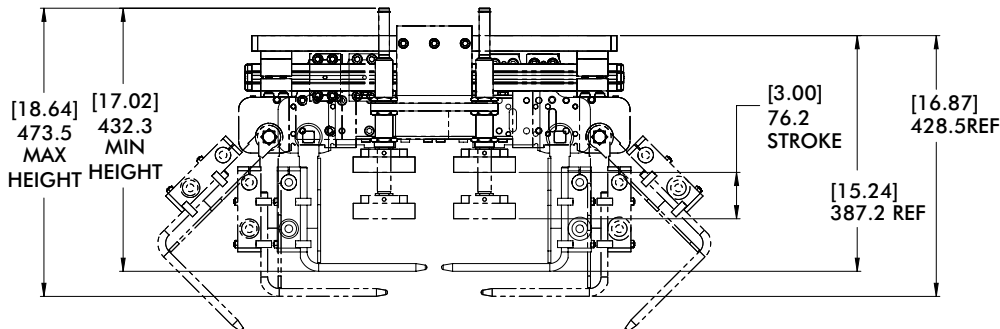

Note: mm/[Inches]



EE-DBG-11

Dimensions and technical information are subject to change without notice

# PALLET PICK AND PLACE OPTION

Bag Gripping and Palletizing Solutions | Dimensions

Model Number	Weight
<b>DBG50-2-PP</b>	[29 lb] 13 kg

Add to base model weight

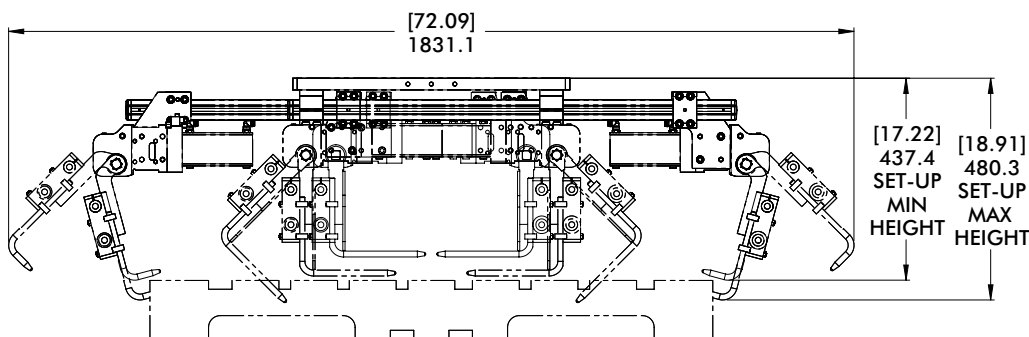
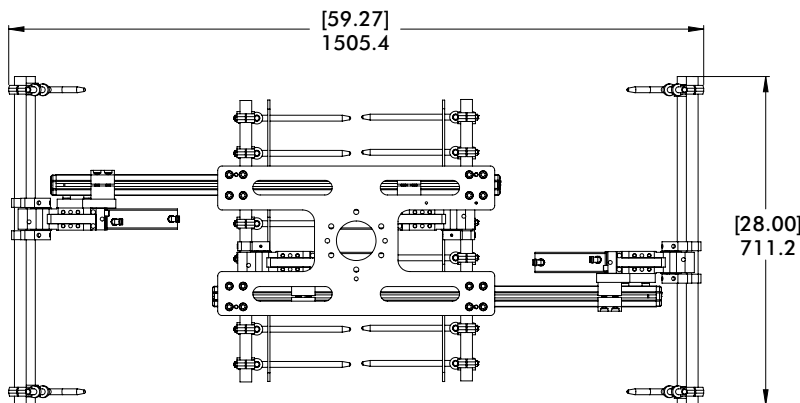
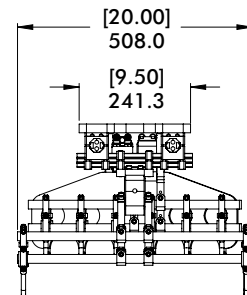
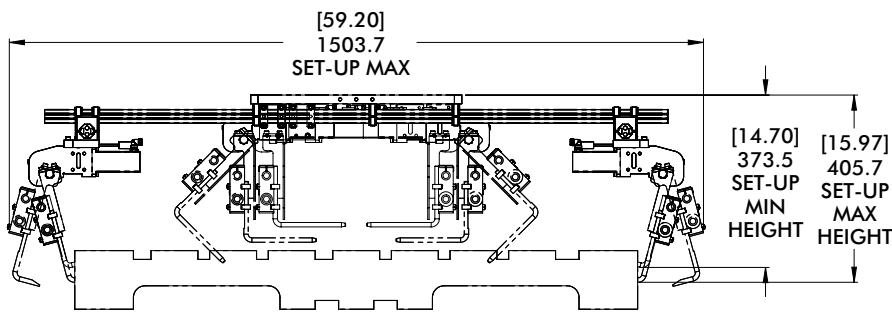
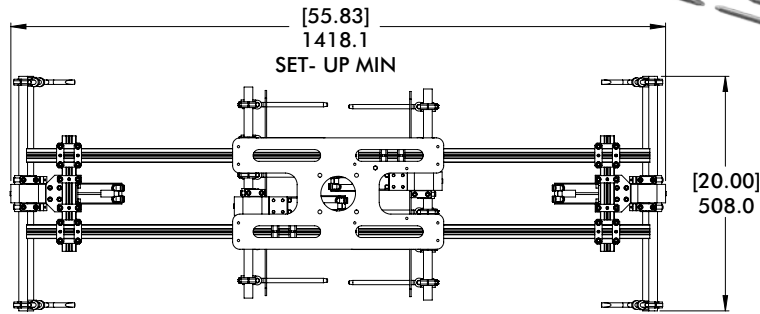
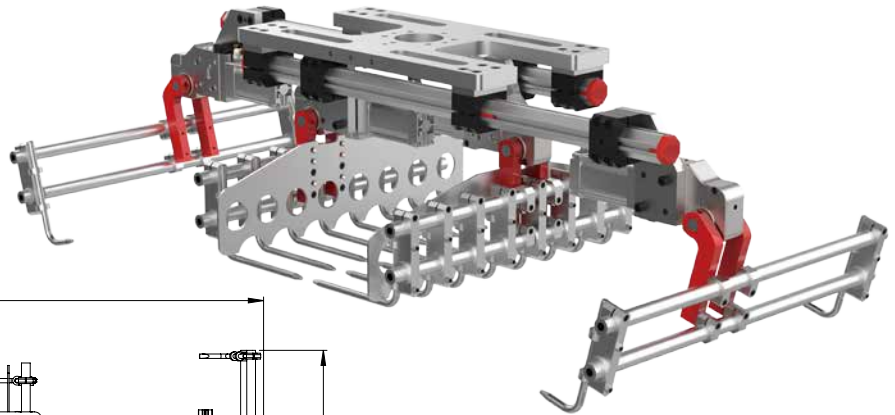

Model Number	Weight
<b>DBG100-2-PP</b>	[48 lb] 22 kg

Add to base model weight

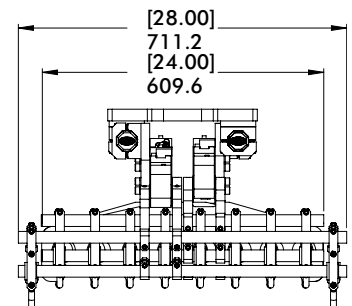

Note: mm/[Inches]

# CONTROLS AND VALVE PACKAGE OPTION

Bag Gripping and Palletizing Solutions | Dimensions

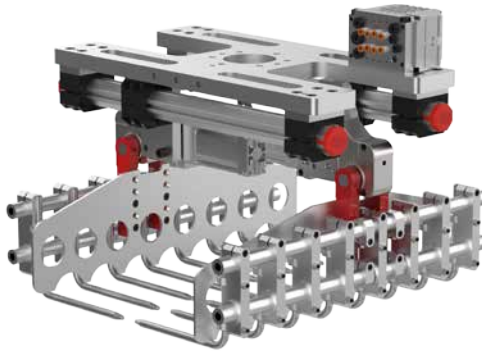

**Model Number**

**DBG50-2-CP**

**Weight**

[5 lb]  
2.3 kg

Add to base model weight

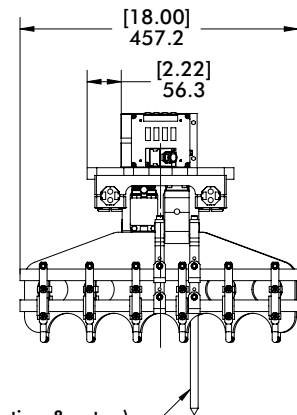
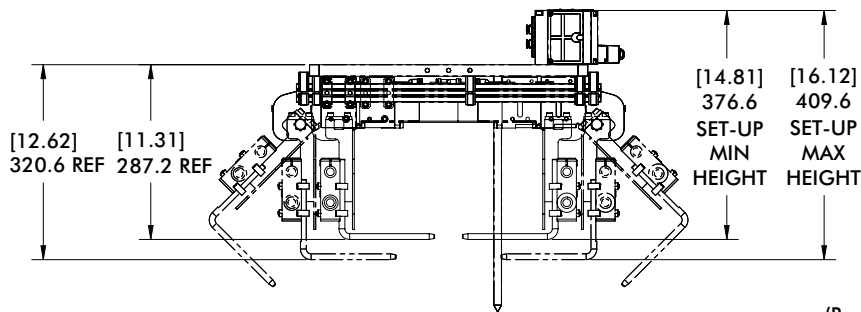

**Model Number**

**DBG100-2-CP**

**Weight**

[5 lb]  
2.3 kg

Add to base model weight

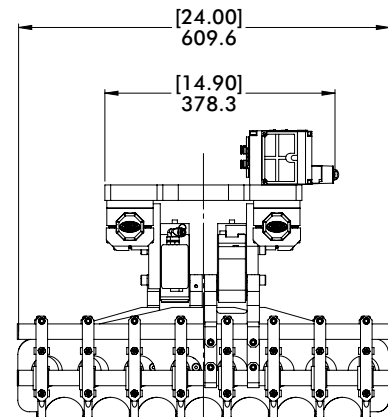
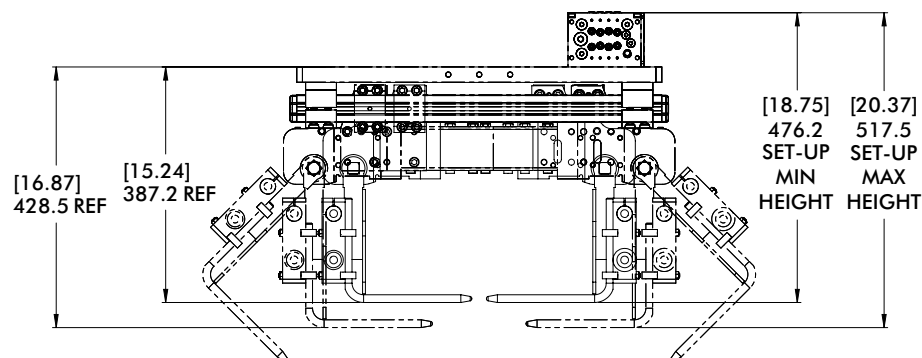

Note: mm/[Inches]

# DBG-2-CP-KIT CONTROLS PACKAGE

Bag Gripping and Palletizing Solutions | Dimensions | Technical Specifications

For Base Model

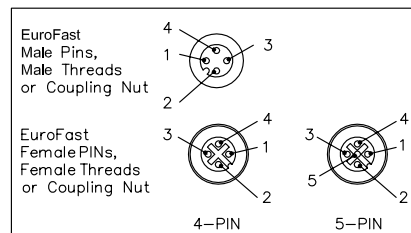
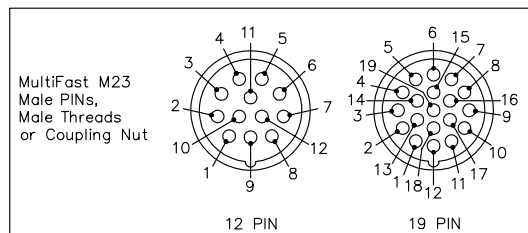
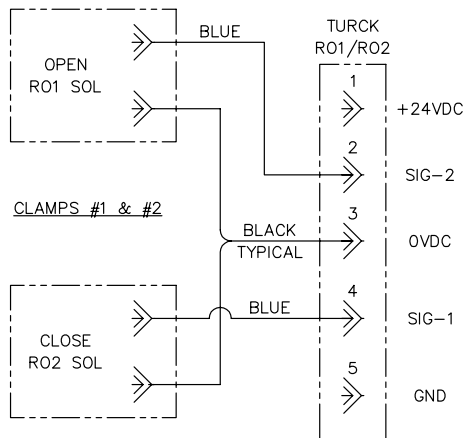
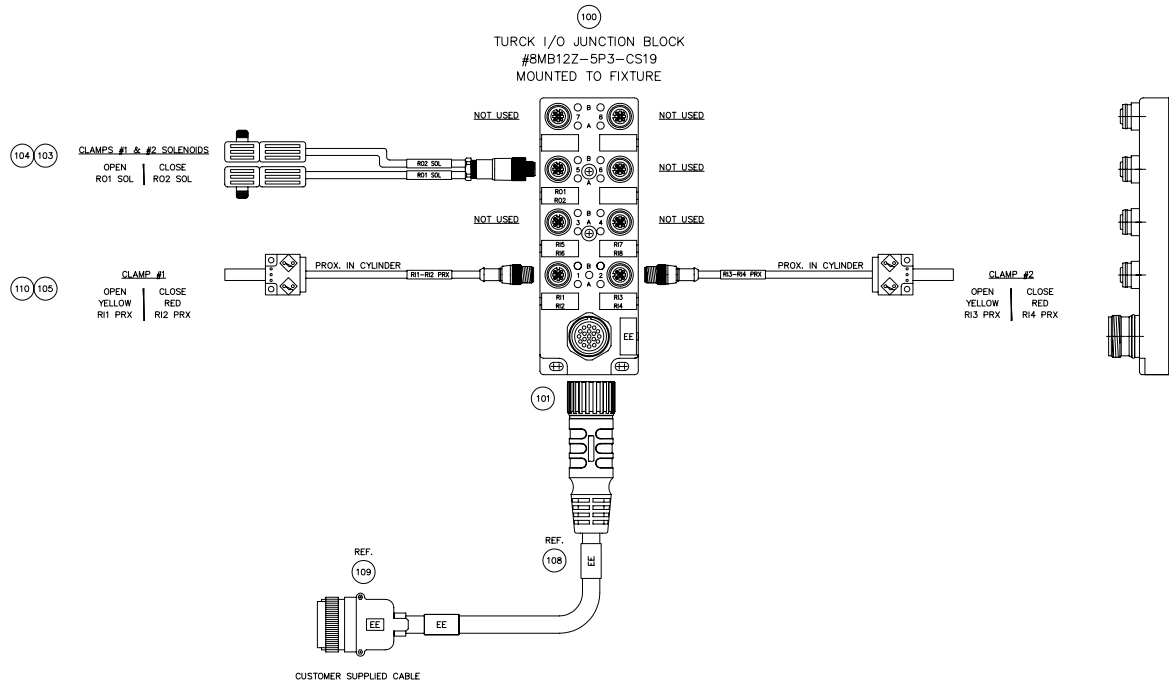

# DBG-2-CP-PU-SP-KIT CONTROL PACKAGE

Bag Gripping and Palletizing Solutions | Dimensions | Technical Specifications

For Slip Sheet Pick and Place

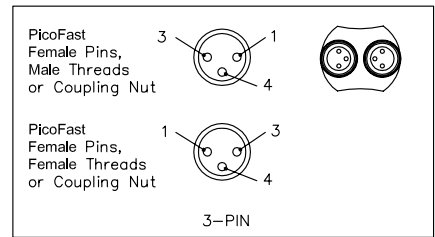
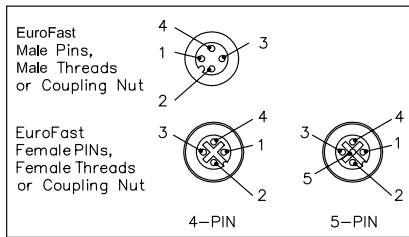
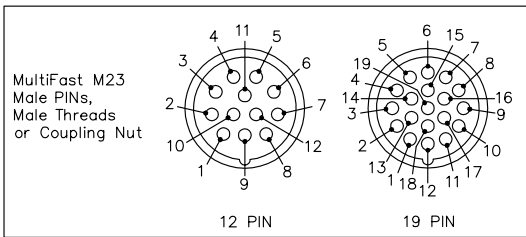
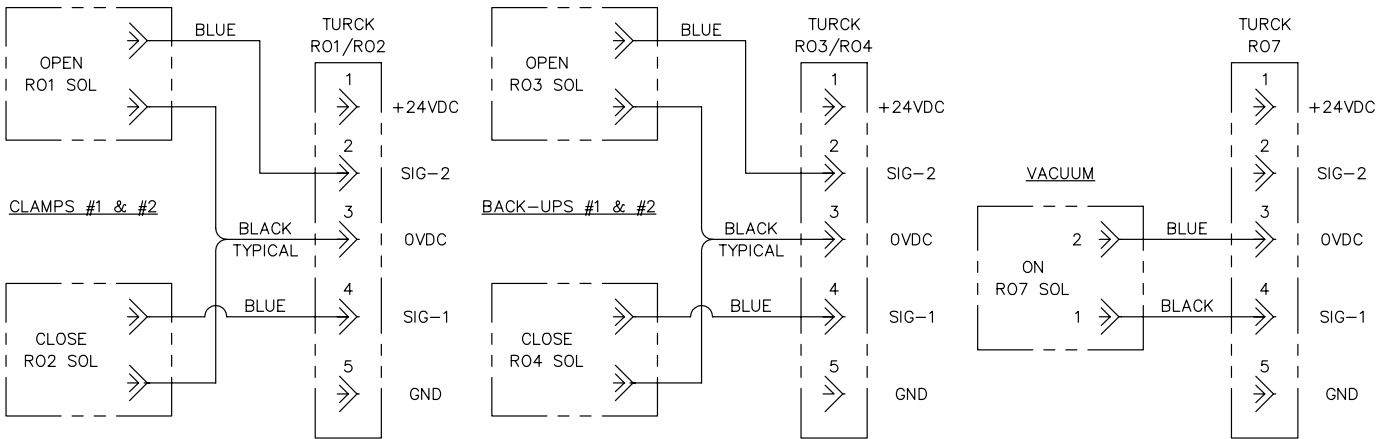
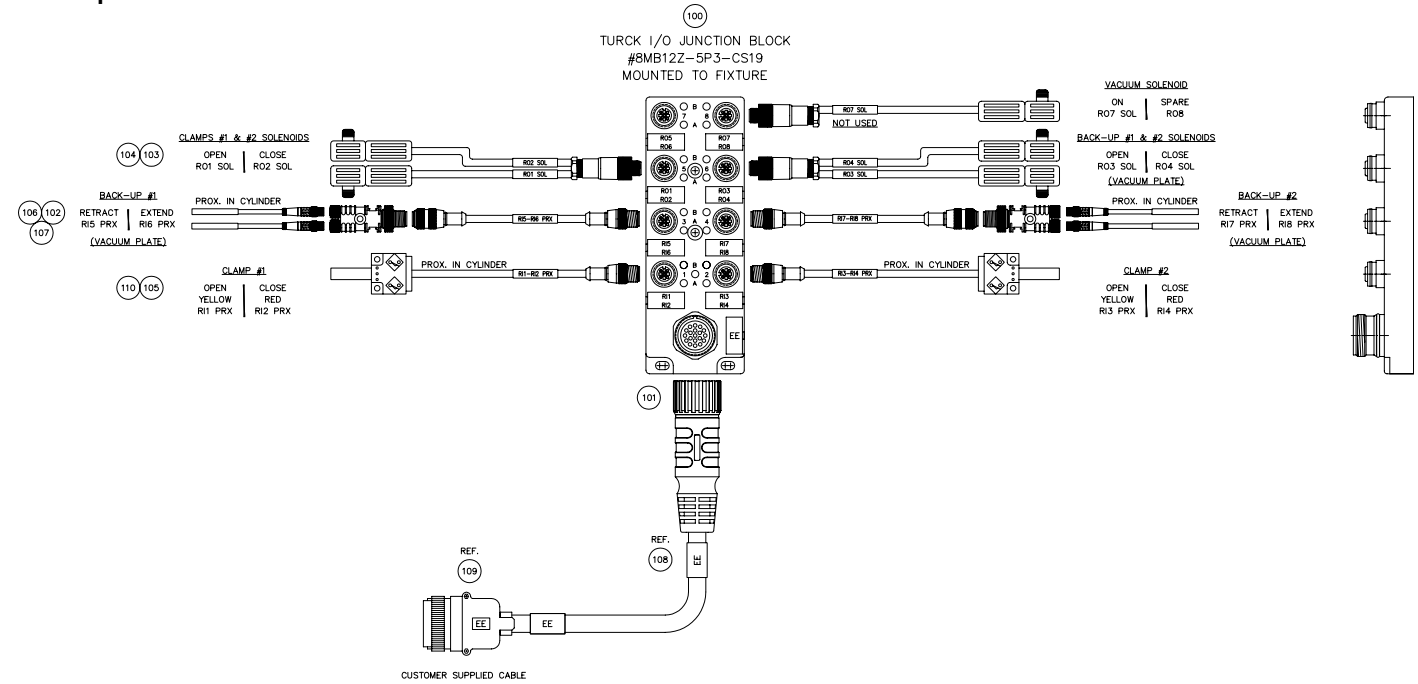

# DBG-2-CP-PU-BU-KIT CONTROLS PACKAGE

Bag Gripping and Palletizing Solutions | Dimensions | Technical Specifications

For Pneumatic Back-up

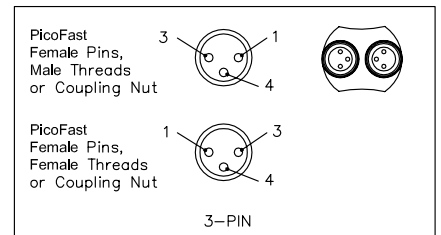
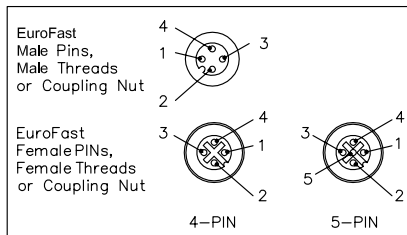
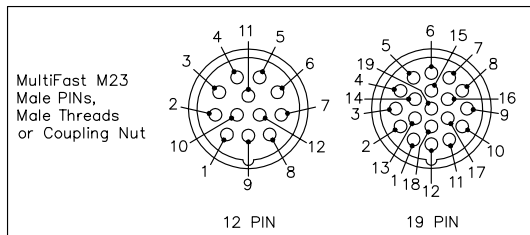
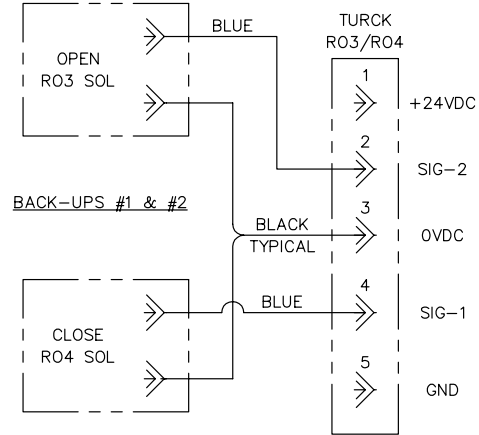
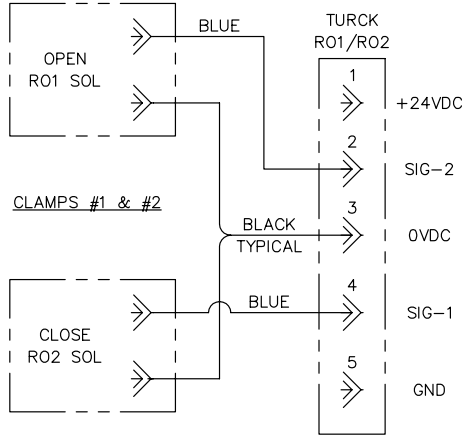
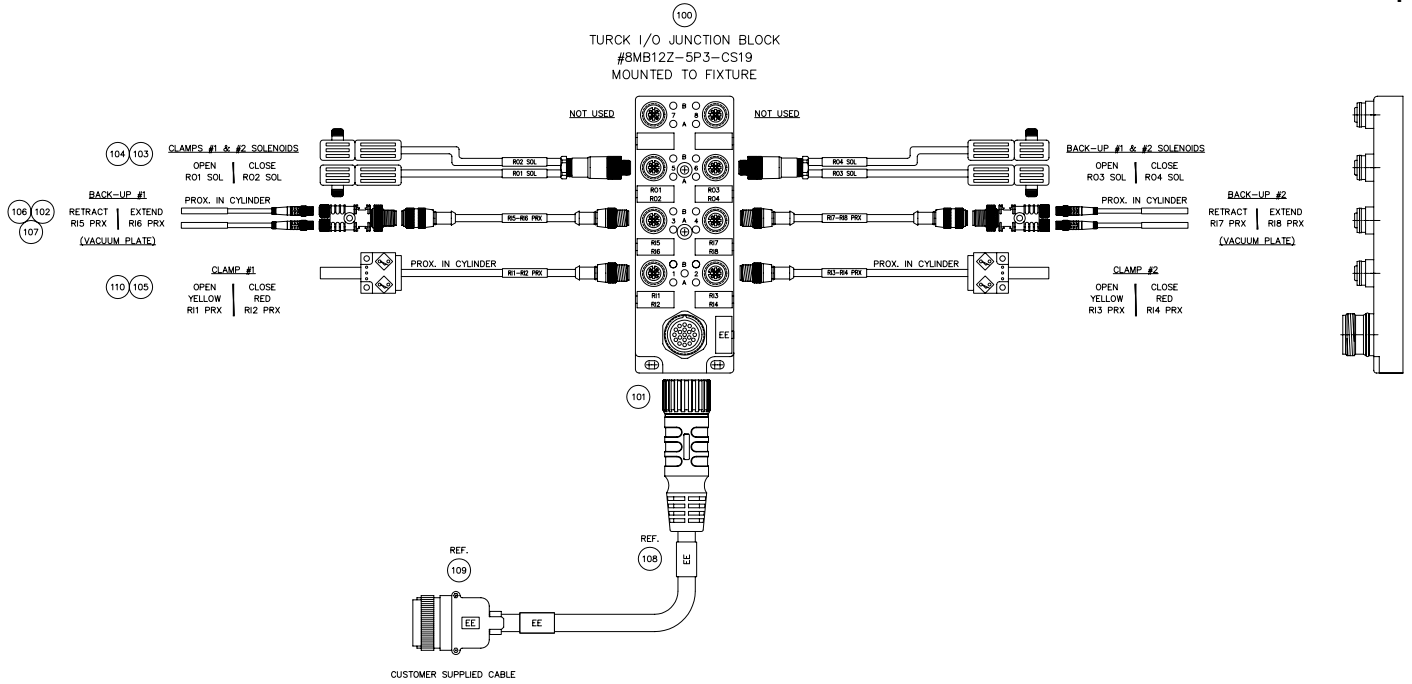



# DBG-2-CP-PP-KIT CONTROLS PACKAGE

Bag Gripping and Palletizing Solutions | Dimensions | Technical Specifications

For Pallet Pick and Place

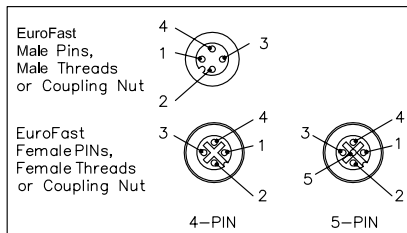
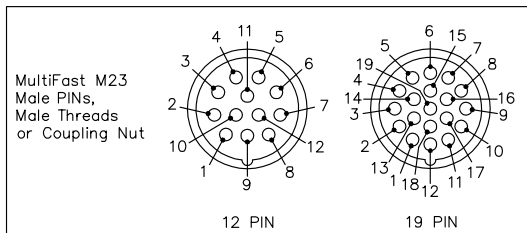
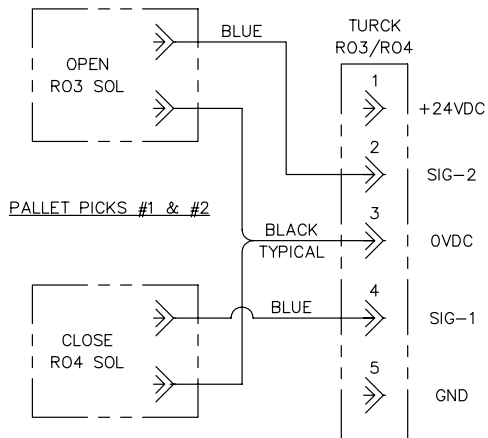
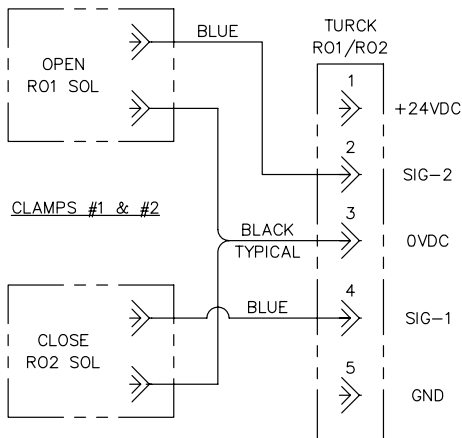
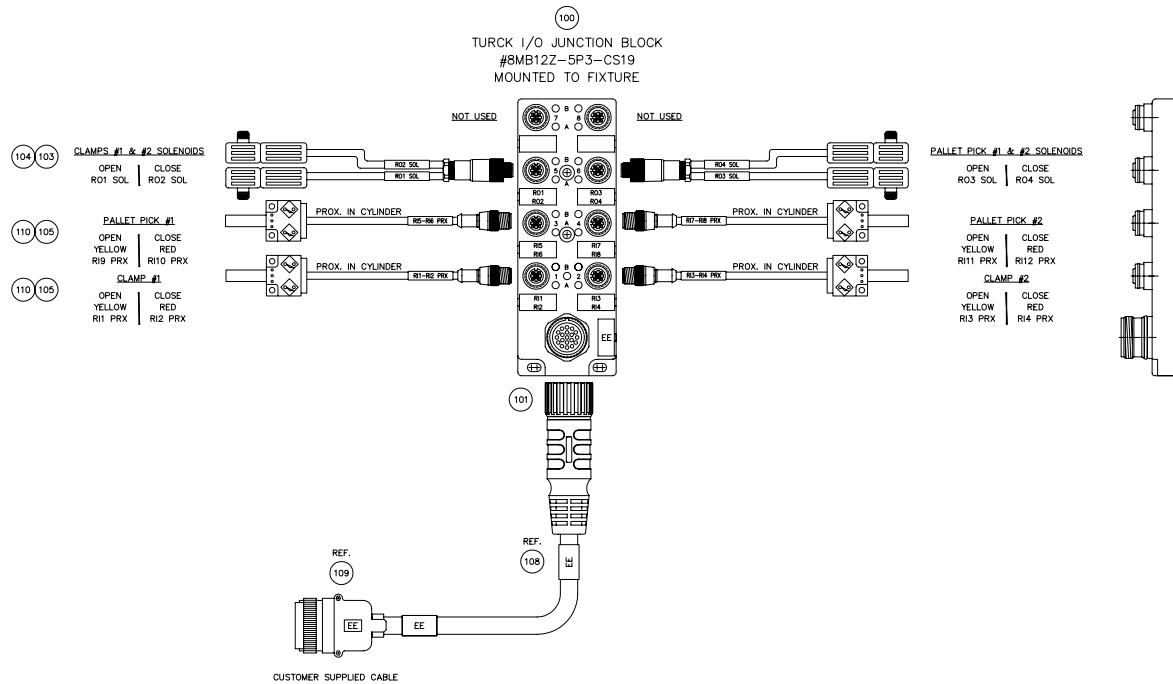

# DBG-CP-PU-SP-PP-KIT CONTROLS PACKAGE

Bag Gripping and Palletizing Solutions | Dimensions | Technical Specifications

For Pallet Pick and Place/Slip Sheet Pick and Place

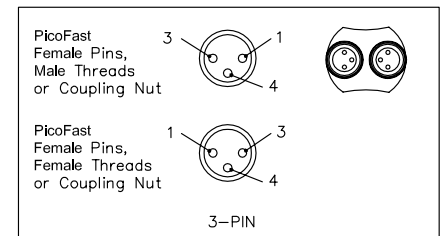
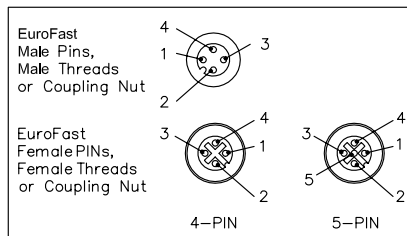
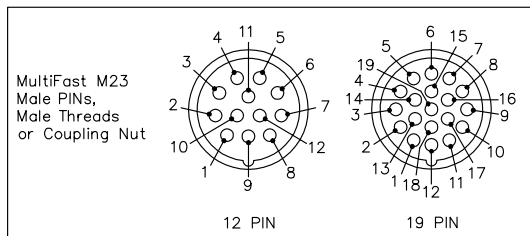
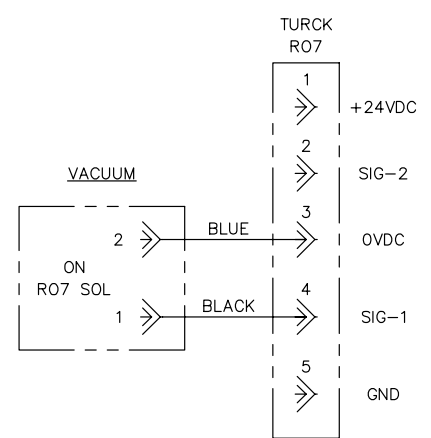
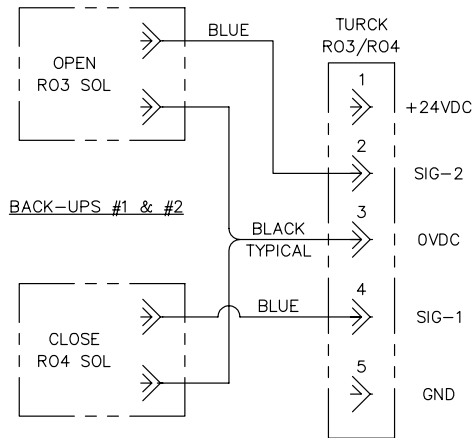
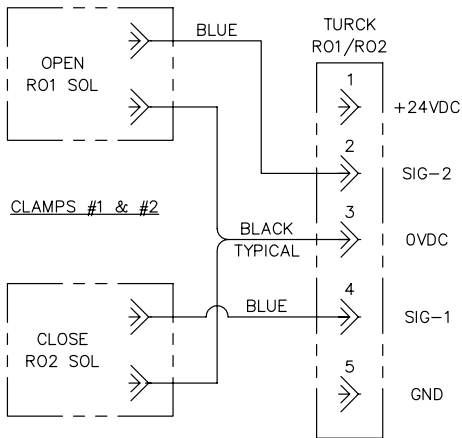
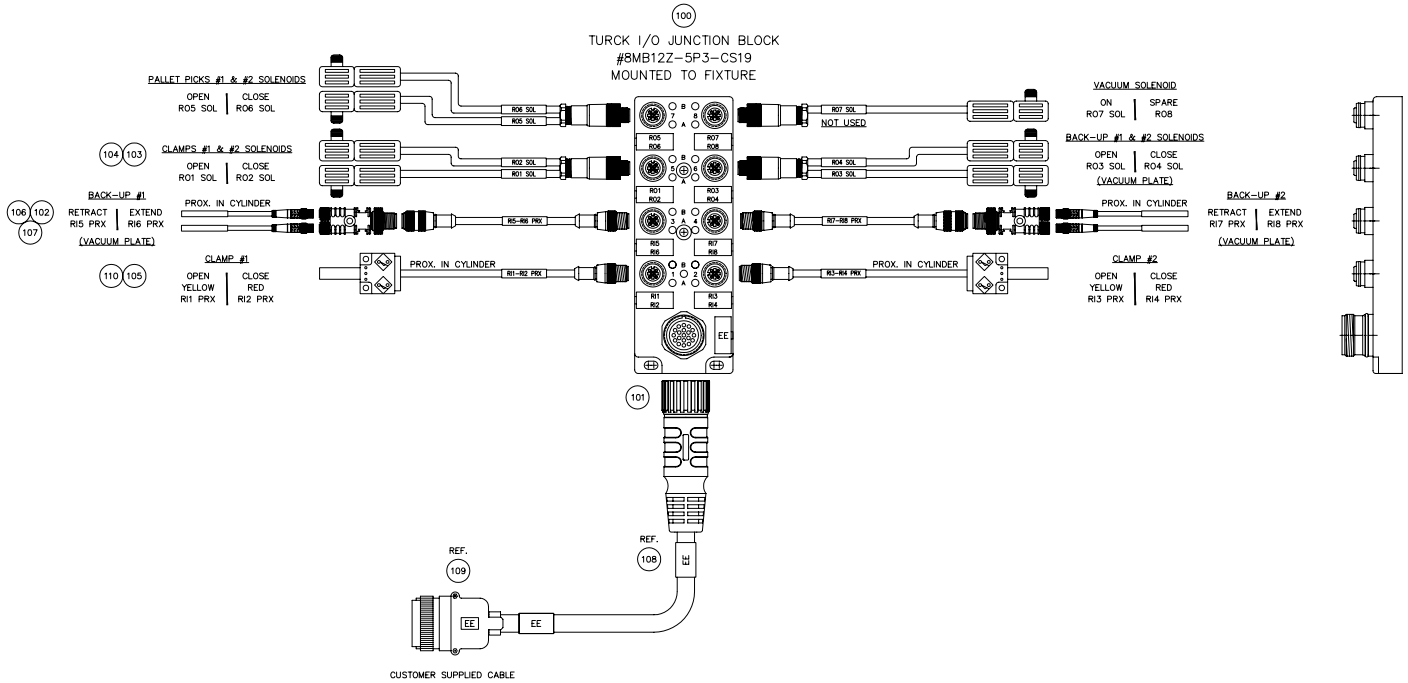

# DBG-CP-PU-BU-PP-KIT CONTROLS PACKAGE

Bag Gripping and Palletizing Solutions | Dimensions | Technical Specifications

For Pallet Pick and Place/Pneumatic Back-up

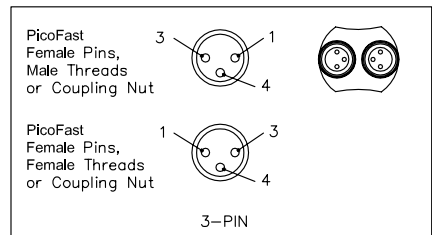
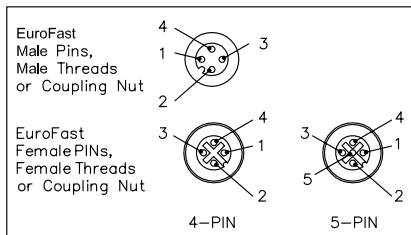
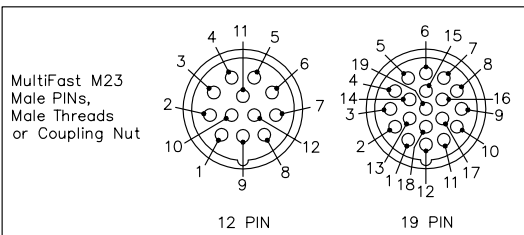
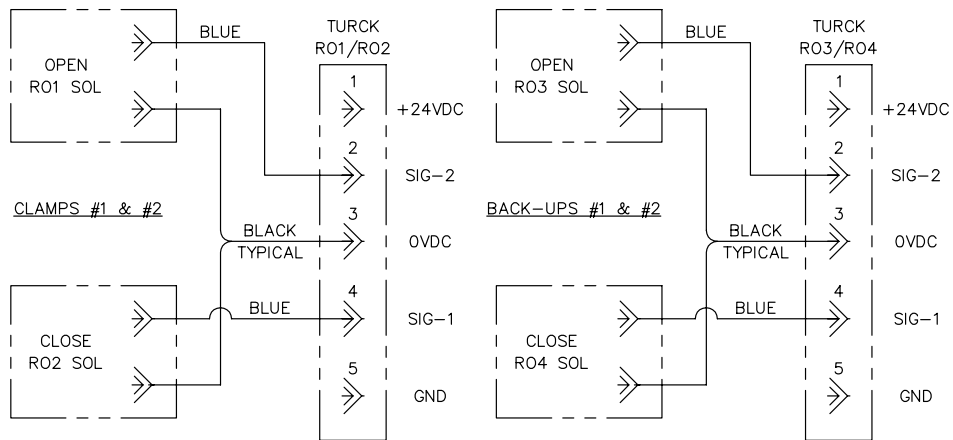
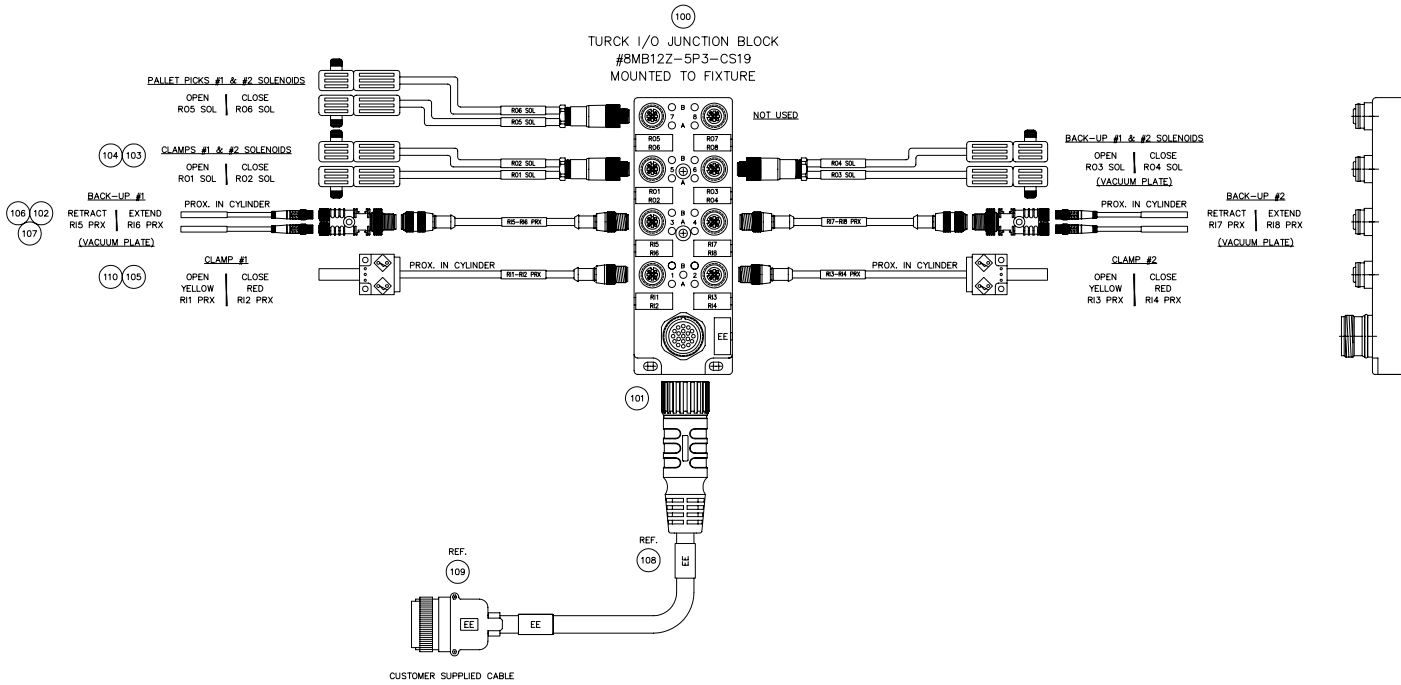

# ROBOT STAND-OFF ADAPTOR

Bag Gripping and Palletizing Solutions | Product Overview

(Sold Separately)

- Aluminum welded construction
- Painted safety orange
- Available in 100, 125, 160 & 200mm bolt circles  
(Custom stand-offs available upon request)
- Bolts for mounting to bag gripper are included

Robot Mount Stand-Off  
with  $\text{\O}125$  Bolt Circle Pattern  
DBG50-2-S04-125BC-KIT

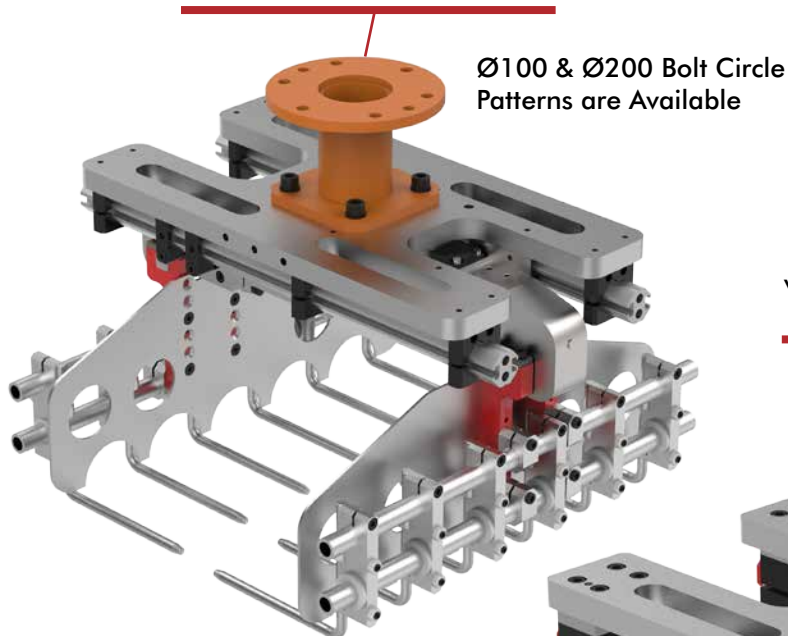

Robot Mount Stand-Off  
with  $\text{\O}160$  Bolt Circle Pattern  
DBG100-2-S04-160BC-KIT

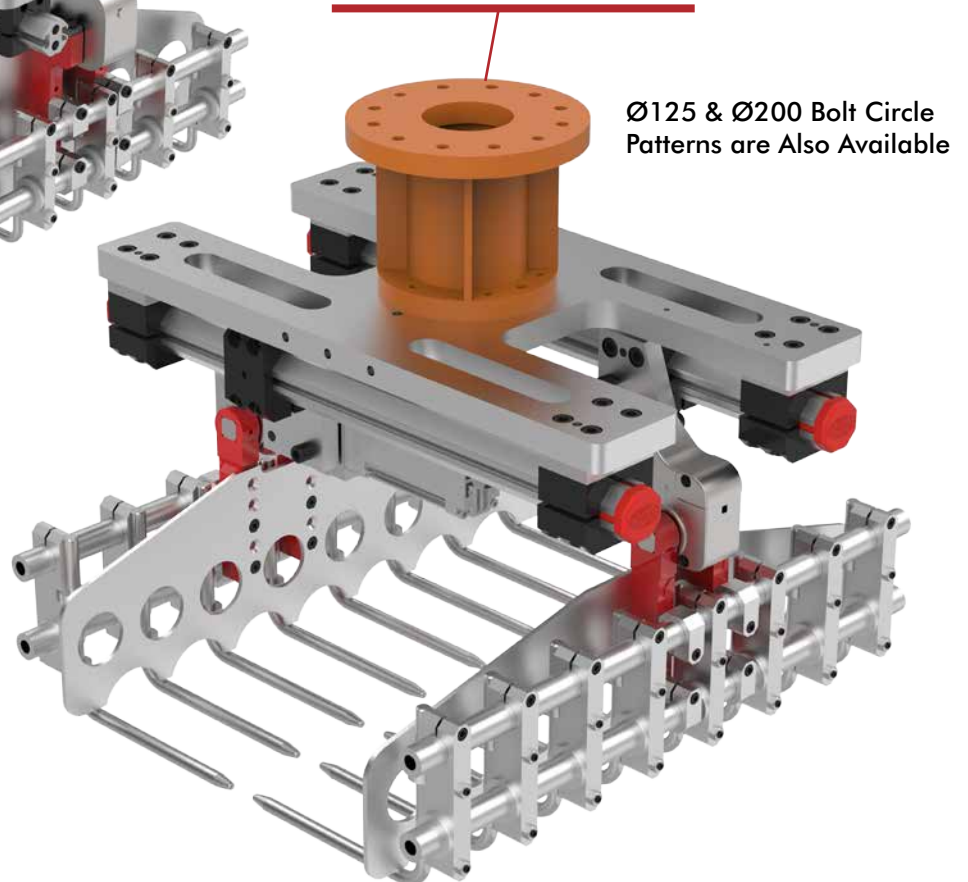

# ROBOT STAND-OFF ADAPTOR

Bag Gripping and Palletizing Solutions | Dimensions | Technical Specifications

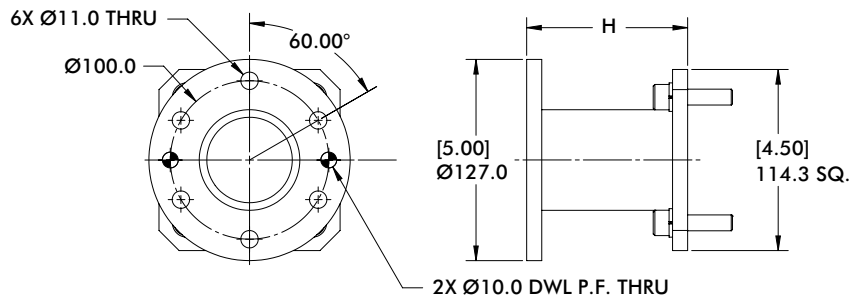

Model Number	H [inch]/mm	Weight
<b>DBG50-2-S04-100BC-KIT</b>	[4.00] 101.6	[4.8 lb] 2.2 kg
<b>DBG50-2-S06-100BC-KIT</b>	[6.00] 152.4	[5.5 lb] 2.5 kg

Material: Aluminum painted safety orange  
(4) M10 SHCS & Lock washers included

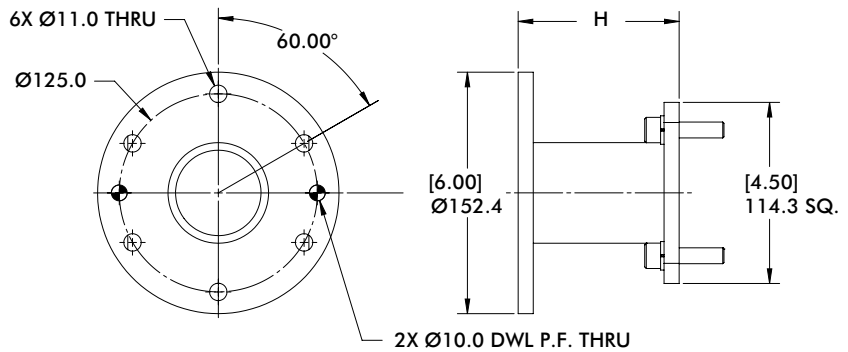

Model Number	H [inch]/mm	Weight
<b>DBG50-2-S04-125BC-KIT</b>	[4.00] 101.6	[5.7 lb] 2.6 kg
<b>DBG50-2-S06-125BC-KIT</b>	[6.00] 152.4	[6.5 lb] 2.9 kg

Material: Aluminum painted safety orange  
(4) M10 SHCS & Lock washers included

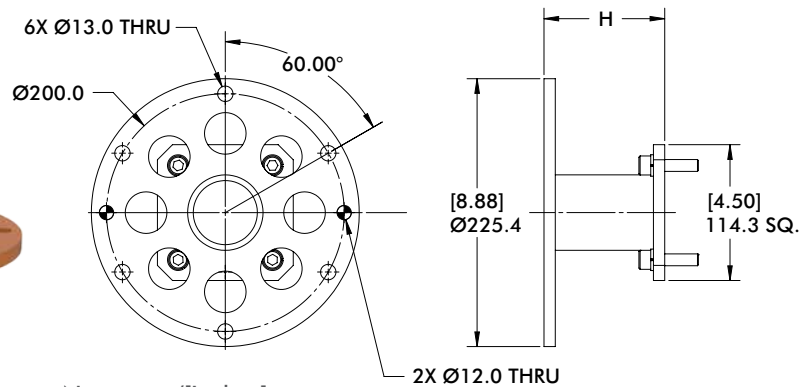

Note: mm/[Inches]

Model Number	H [inch]/mm	Weight
<b>DBG50-2-S04-200BC-KIT</b>	[4.00] 101.6	[7.9 lb] 3.6 kg
<b>DBG50-2-S06-200BC-KIT</b>	[6.00] 152.4	[8.7 lb] 3.9 kg

Material: Aluminum painted safety orange  
(4) M10 SHCS & Lock washers included

# ROBOT STAND-OFF ADAPTOR

Bag Gripping and Palletizing Solutions | Dimensions | Technical Specifications

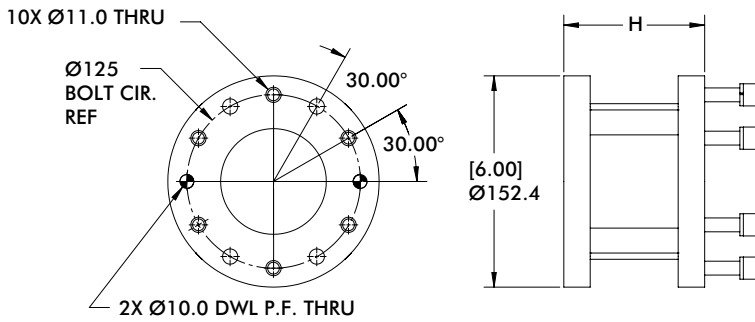

Model Number	H [inch]/mm	Weight
<b>DBG100-2-S04-125BC-KIT</b>	[4.00] 101.6	[4.4 lb] 2.0 kg
<b>DBG100-2-S06-125BC-KIT</b>	[6.00] 152.4	[5.2 lb] 2.4 kg

Material: Aluminum painted safety orange  
 (6) M10 SHCS & Lock washers included

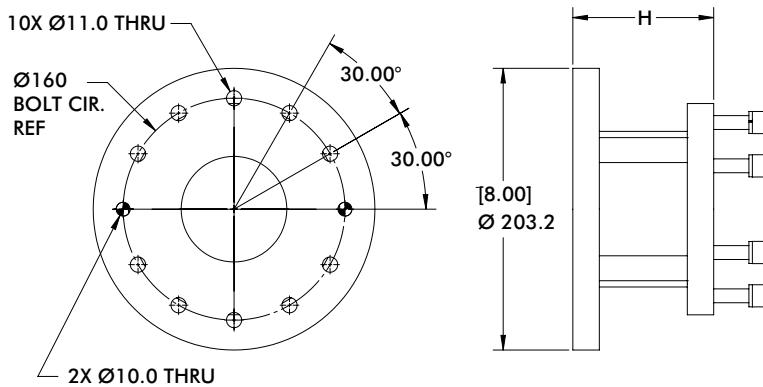

Model Number	H [inch]/mm	Weight
<b>DBG100-2-S04-160BC-KIT</b>	[4.00] 101.6	[6.0 lb] 2.7 kg
<b>DBG100-2-S06-160BC-KIT</b>	[6.00] 152.4	[6.8 lb] 3.1 kg

Material: Aluminum painted safety orange  
 (6) M10 SHCS & Lock washers included

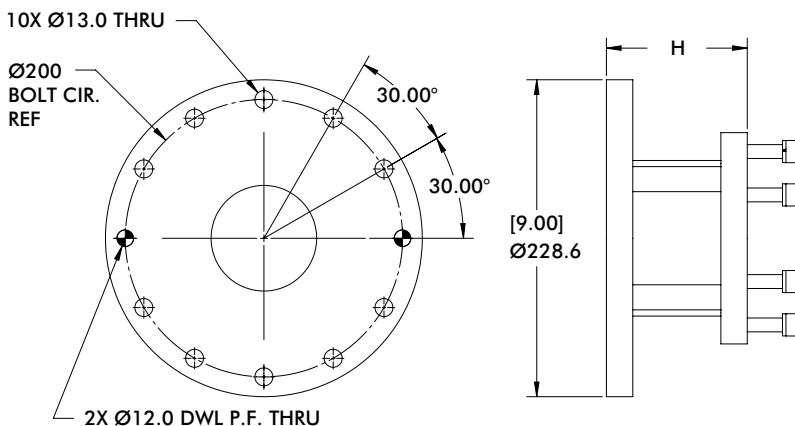

Note: mm/[Inches]

Model Number	H [inch]/mm	Weight
<b>DBG100-2-S04-200BC-KIT</b>	[4.00] 101.6	[6.9 lb] 3.1 kg
<b>DBG100-2-S06-200BC-KIT</b>	[6.00] 152.4	[7.7 lb] 3.5 kg

Material: Aluminum painted safety orange  
 (6) M10 SHCS & Lock washers included