

# BUTTRESS SERIES

## CARVER Clamps | Product Overview

### Features:

These workholding clamps are designed for use on thin or low-profile workpieces replacing ordinary strap clamps. They feature a self-aligning swiveling pivot which allows the tightening bolt to always remain vertical, preventing any side forces. The two-point contact offered by Models T614-0 and T614-1 also provides greater stability to the workpiece. Ideally suited for manual die clamping. Eliminates the need for step blocks or riser blocks.



### Technical Information, Holding Capacities

Holding Capacity	Working Height Range	For screw diameter	Model	Weight [lbs.] kg
	[0-1.75"] 0-45	[1/2"] M12	<b>T614-0</b>	[1.5] 0,6
	[0-2.25"] 0-57	[5/8"] M16 or [3/4"] M20	<b>T614-1</b>	[5.8] 2,7
	[0-3.00"] 0-75	[1"] M24	<b>T614-2</b>	[9.5] 4,3

# BUTTRESS SERIES

## CARVER Clamps | Dimensions

Holding capacity [2900 lbf] 13kN  
Clamping height [1.75] 45mm max.  
**Model T614-0**

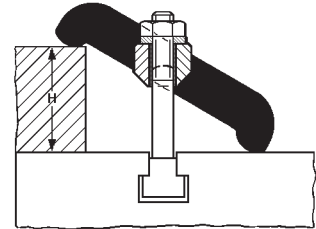
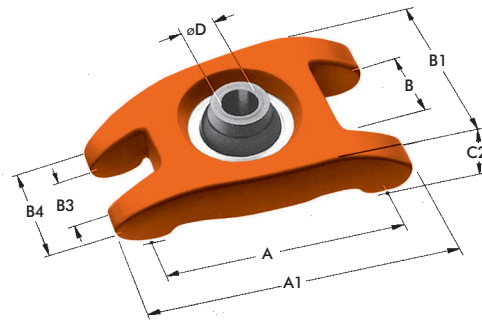

Holding capacity [14000 lbf] 62.5kN  
Clamping height [2.25] 57mm max.  
**Model T614-1**  
Delivery includes reducing bush with inner diameter 17 [0.67].  
Reducer bushing is standard equipment

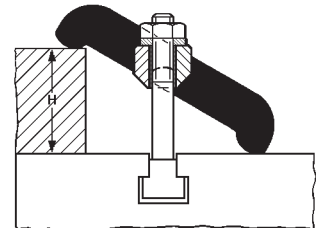
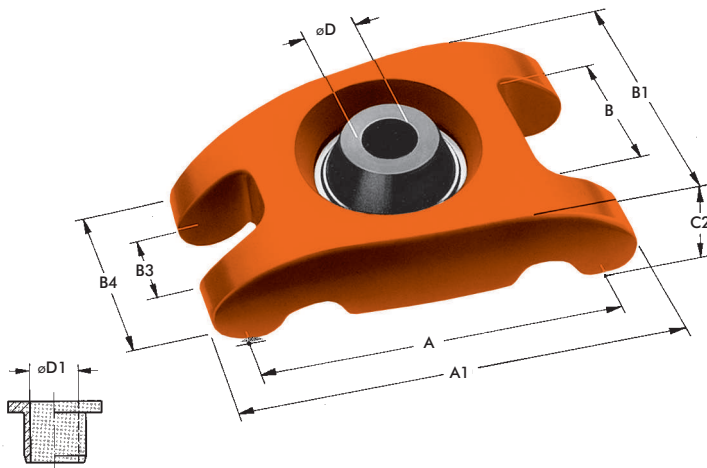

Holding capacity [18000 lbf] 80kN  
Clamping height 75 [3.00] max.  
**Model T614-2**

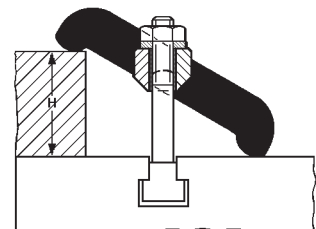
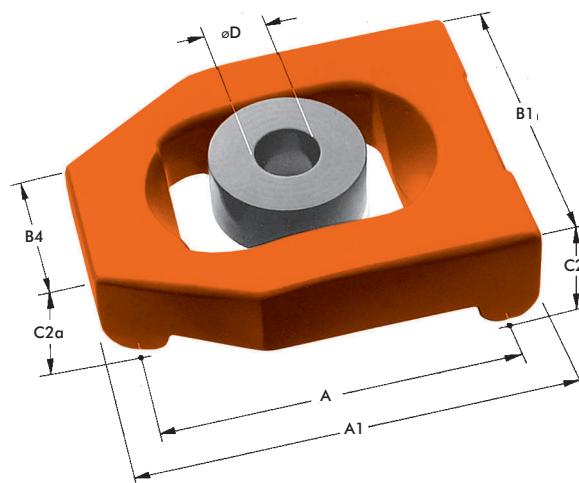

Model	[inch] mm									
	A	A1	B	B1	B3	B4	C2	C2a	ØD	ØD1
<b>T614-0</b>	[3.54] 90	[4.34] 110	[1.41] 36	[2.59] 66	[0.78] 40	[1.56] 40	1.02] 26	-	[0.51] 13	-
<b>T614-1</b>	[5.28] 134	[6.31] 160	[2.09] 53	[3.94] 100	[1.14] 29	[2.56] 65	[1.81] 46	-	[0.83] 21	[0.67] 17
<b>T614-2</b>	[5.83] 148	[6.69] 170	-	[5.13] 130	-	[2.56] 65	[1.97] 50	[1.57] 40	[1.02] 26	-