

548, 578 SERIES

Heavy-Duty Vertical Hold Down Clamps | Product Overview

Features:

- Large bar guides for lateral stability
- Hardened steel pins and bushings for long life
- Replaceable pins

Applications:

- Assembly & test
- Light machining
- Welding
- Heavy duty clamping requirements

548
Straight Base
Solid Bar



578
Straight Base
Solid Bar



Technical Information

Model	Max. Holding Capacity	Clamp Bar Opening (+10°)	Handle Opening (+10°)	Weight
548	11100N [2500lbf]	199°	129°	2,40kg [5.30lbs]
578	17800N [4000lbf]			4,14kg [9.12lbs]

Holding Capacities | Dimensions

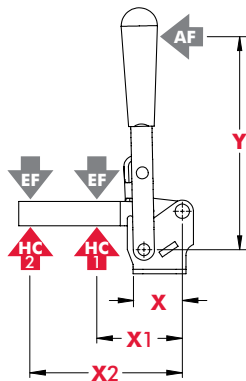

Model	X	X1	X2	Y	±HC1	±HC2	±EF(X1):AF	±EF(X2):AF
548	[2.75] 70	[3.50] 89	[6.00] 152	[7.50] 190	[2500lbf] 11100N	[1500lbf.] 6680N	4.5:1	3.4:1
578	[4.25] 108	[4.50] 114	[7.00] 178	[10.31] 262	[4000lbf] 17800N	[2500lbf.] 11100N	7.6:1	4.2:1

Dimensions shown "mm [inch]" ± HC = Holding Capacity, EF = Exerting Force, AF = Applied Force
See page MC-TEC-4 for additional information.

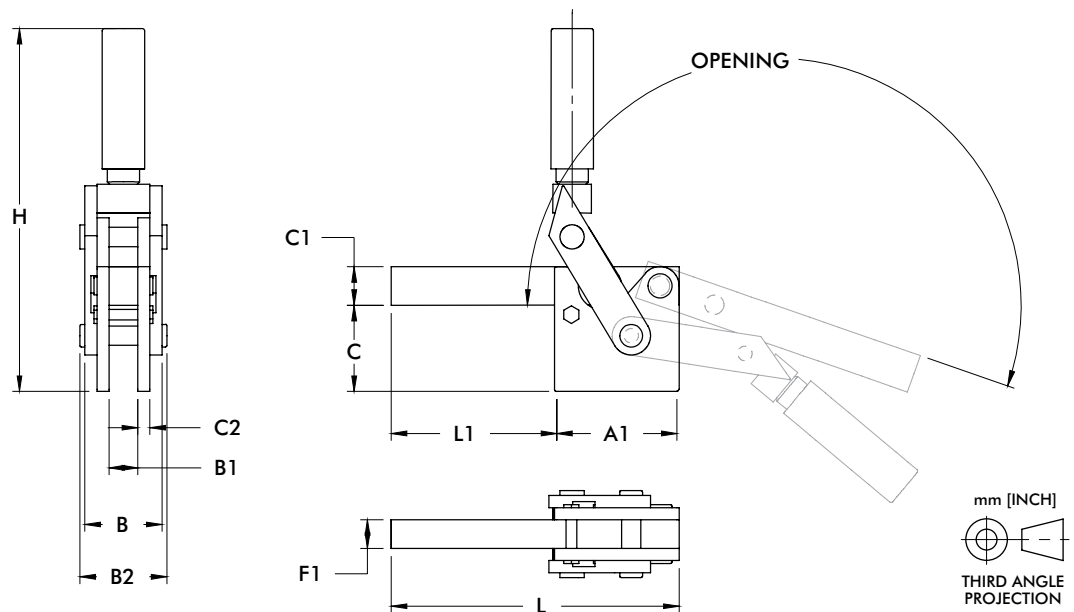

Model	A1	B	B1	B2	C	C1	C2	F1	H	L	L1
548	[3.25] 82,6	[2.01] 51	[0.75] 19,1	[2.26] 57,5	[2.24] 56,9	[1.00] 25,4	[0.31] 7,9	[0.75] 19,1	[9.45] 240	[7.50] 190,5	[4.25] 107,9
578	[4.02] 102,1	[2.38] 60,5	[0.87] 22,1	[2.70] 68,6	[2.79] 70,9	[1.26] 32	[0.37] 9,5	[0.87] 22,1	[11.04] 280,3	[8.62] 219	[4.61] 117,1