

528 SERIES

Heavy-Duty Vertical Hold Down Clamps | Product Overview

Features:

- Hardened steel bushings at pivot points for long life
- Solid bar may be modified to suit application requirements

Applications:

- Assembly & test
- Light machining
- Welding
- Medium to heavy duty clamping requirements

528
Flanged Base
Solid Bar



528-F ⓘ
Front Mount
Base Solid Bar



Technical Information

Model	Max. Holding Capacity	Clamp Bar Opening (+10°)	Handle Opening (+10°)	Weight
528	4450 N [1000 lbf]	180°	177°	[2.50lbs] 1,13kg
528-F ⓘ				

ⓘ This item is available upon request

Holding Capacities | Dimensions

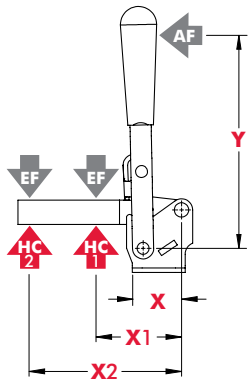

Model	X	X1	X2	Y	±HC1	±HC2	±EF(X1):AF	±EF(X2):AF
528	[1.38]	[3.50]	[6.00]	[5.50]	[1000lbf.]	[580lbf.]	23:1	12:1
528-F	35	89	152	140	4450N	2580N		

Dimensions shown "mm [inch]" ± HC = Holding Capacity, EF = Exerting Force, AF = Applied Force
See page MC-TEC-4 for additional information.

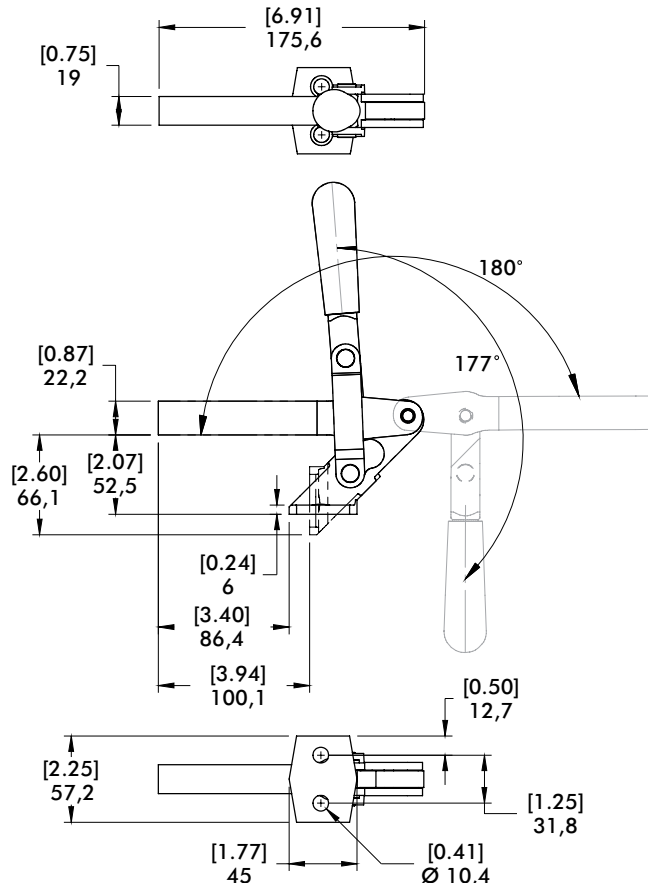
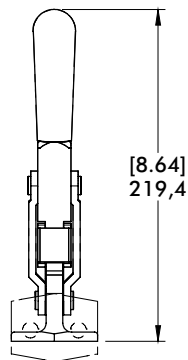

mm [INCH]
THIRD ANGLE PROJECTION