

2007 SERIES

Vertical Hold Down Clamps | Product Overview

Features:

- Large hand clearance for improved safety
- Bolt pattern interchangeable with 207 Series
- Over two times the holding capacity of 207 Series
- Hardened bushings at key pivot points
- Near vertical clamping contact

Applications:

- Checking fixtures
- Assembly & test
- Light machining
- Woodworking

Also Available:

See page MC-ACC-1 for accessories
Accepts M8 or 5/16 spindle accessories

Covered under one or more U.S./International Patents

2007-U
Flanged Base
U-Bar



2007-U-LS-BLK ⓘ
Blackout Series
Flanged Base
U-Bar



2007-S
Flanged Base
Solid Bar



2007-UB
Straight Base
U-Bar



2007-UB-LS-BLK ⓘ
Blackout Series
Straight Base
U-Bar



2007-SB
Straight Base
Solid Bar



2007-UR
Flanged Base
U-Bar
with
DESTACO®
Toggle Lock
Plus



2007-SR ⓘ
Flanged Base
Solid Bar
with
DESTACO®
Toggle Lock
Plus



2007-UBR
Straight Base
U-Bar
with
DESTACO®
Toggle Lock
Plus



2007-SBR ⓘ
Straight Base
Solid Bar
with
DESTACO®
Toggle Lock
Plus



Technical Information

Model	Max. Holding Capacity	Clamp Bar Opening (+10°)	Handle Opening (+10°)	Weight	Accessories (Supplied)		
					Bolt Retainer	Spindle Assembly	Flanged Washers
2007-U	4450 N [1000 lbf]	76°	64°	0,54kg [1.20lbs]	--	2007208-M	507107
2007-U-LS-BLK ⓘ					--	--	507107-BLK
2007-S					2007115-E	--	--
2007-UB					--	2007208-M	507107
2007-UB-LS-BLK ⓘ					--	--	507107-BLK
2007-SB					2007115-E	--	--
2007-UR					--	2007208-M	507107
2007-SR ⓘ					2007115-E	--	--
2007-UBR					--	2007208-M	507107
2007-SBR ⓘ					2007115-E	--	--

ⓘ This item is available upon request

Vertical Hold Down Clamps | Holding Capacities

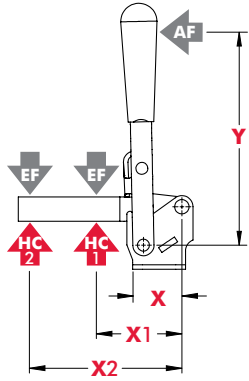

Model	X	X1	X2	Y	±HC1	±HC2	±EF(X1):AF	±EF(X2):AF
2007-()	[1.59] 40,5	[1.95] 49,5	[3.92] 99,5	[5.16] 131	[1000lbf.] 4450N	[470lbf.] 2090N	10:1	5.3:1

Dimensions shown "mm [inch]" ± HC = Holding Capacity, EF = Exerting Force, AF = Applied Force
See page MC-TEC-4 for additional information.

Dimensions | -U/-S/-UB/-SB/-UR/-SR/-UBR/-SBR

2007-U
Flanged Base
U-Bar

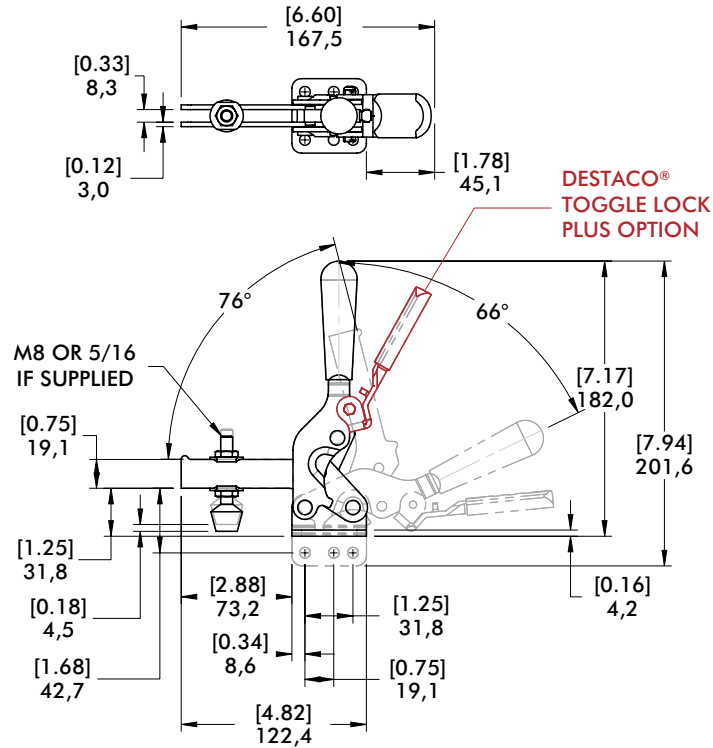
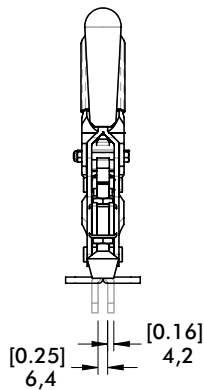

2007-SB
Straight Base
Solid Bar

